

AIRMAN

INSTRUCTION MANUAL ENGINE GENERATOR

SDG60S-3A6

(DOUBLE VOLTAGE TYPE)



Please be sure to read this manual
before using this machine.

HOKUETSU INDUSTRIES CO., LTD.

Preface

This manual explains and illustrates proper handling of the unit, method of daily inspection and maintenance to enhance the performance of AIRMAN's generators.

In order to use a machine safely, people with sufficient knowledge and sufficient technology need to deal with it.

Before operating the unit, read the manual carefully, fully understand its operation and maintenance requirement. Maintain "SAFETY OPERATION AND PROPER MAINTENANCE OF THE UNIT".

Be sure to follow safety warnings and cautions given in the manual. Unsafe operation could cause serious injury or death.

For details of handling, maintenance and safety of the engine, see the Engine Operation Manual.

Keep the manual available at all times for the operator or safety supervisor.

If the manual is lost or damaged, place an order with your dealer for another copy.

Be sure that the manual is included with the unit when it is handed over to another user.

There may be some inconsistency in detail between the manual and the actual machine due to improvements of the machine. Ask your dealer if you have any questions or problems.

If you have any questions about the unit, please inform us the model and serial number. A plate stamped with the model and serial number is attached to side of the unit.

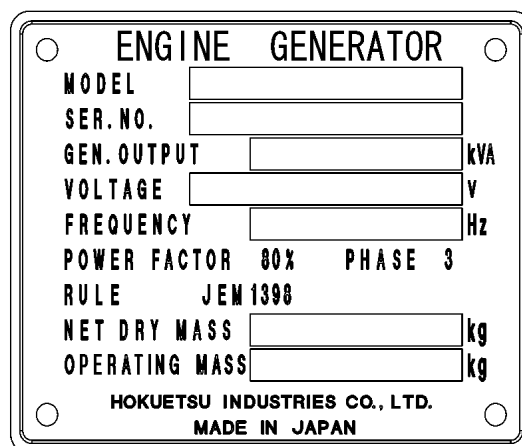

A040491

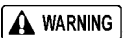

Table of Contents

1. Safety	1-1
1.1 Caution before Operation	1-2
1.2 Caution during Operation	1-4
1.3 Caution during Inspection and Maintenance	1-6
1.4 Safety Warning Labels	1-8
2. Part Names	2-1
2.1 Unit Appearance and Part Names	2-1
2.2 Internal Components.....	2-2
3. Installation	3-1
3.1 Transporting Unit	3-1
3.2 Place and Conditions of Unit Installation	3-2
3.3 Leakage Protection Device and Grounding Method.....	3-5
3.4 Selecting Cable	3-7
3.5 Selector Valve of Fuel Pipe.....	3-8
4. Operation	4-1
4.1 Instrument panel	4-1
4.2 Protection device	4-2
4.3 Check Frequency Selection Switch for AVR	4-4
4.4 How To Switch Voltages.....	4-5
4.5 Connecting Load.....	4-6
4.6 Engine Oil·Coolant·Fuel	4-10
4.7 Check before Starting the Machine.....	4-11
4.8 Operation and Stopping.....	4-14
5. Periodic Inspection/Maintenance	5-1
5.1 Important items at Periodic inspection and Maintenance or after Maintenance	5-1
5.2 Daily Inspection and keeping Operation Log	5-2
5.3 Periodic Replacement of Parts	5-2
5.4 Periodic Inspection List.....	5-3
5.5 Maintenance	5-4
6. Maintenance/Adjustment	6-1
6.1 Maintenance of Battery	6-1
6.2 Troubleshooting.....	6-3
7. Storage of the Unit	7-1
7.1 Preparation for Long-term Storage	7-1
8. Specifications	8-1
8.1 Specifications.....	8-1
8.2 Outline drawing	8-2
9. Wiring Diagram	9-1
9.1 Generator Wiring Diagram.....	9-1
9.2 Engine Wiring Diagram.....	9-2

1.Safety

This manual explains and illustrates general requirements for safety and cautions for safety.

Please read these safety requirements carefully and fully understand the contents before starting the machine.

For your better recognition, according to the degree of potential danger harmful to a human body, safety messages are classified into three hierarchical categories, namely, , , and  with a caution symbol  - attached to each message.

When one of these messages is found, please take preventive measures for safety to carry out “SAFETY OPERATION AND PROPER MAINTENANCE OF THE UNIT”.



DANGER indicates an imminently hazardous situation which, if not avoided, will result in death or serious injury. This signal word is to be limited to the most extreme situations.



WARNING indicates a potentially hazardous situation which, if not avoided, could result in death or serious injury.

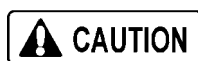

CAUTION indicates a potentially hazardous situation which, if not avoided, may result in minor or moderate injury. It may also be used to alert against unsafe practices.



IMPORTANT indicates important caution messages for the performance or durability of the unit, which has no concern to injury or accident of or to a human body.

Follow warnings mentioned in this manual. This instruction manual does not describe all safety items. We, therefore, advise you to pay special attention to all items (even though they may not be described in the manual) for your safety.

1.Safety

1.1 Caution before Operation



WARNING

Follow the safety instructions

- Read each instruction plate which is displayed in the manual or on the machine carefully, understand its content and follow the indications thereof.
- Keep the Safety Warning labels clean. When they are damaged or missing, apply new ones.
- Do not modify the machine without prior approval. The safety may be compromised, functions may be deteriorated, or machine life may be shortened.
- Never use the machine for the other purposes than power supply. Otherwise, serious accidents may occur.

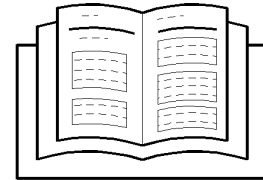

TR0086



WARNING

Ventilation

- Exhaust gas from the engine is poisonous, and could cause casualties when it is inhaled.
Avoid using the machine in an insufficiently ventilated building or a tunnel.

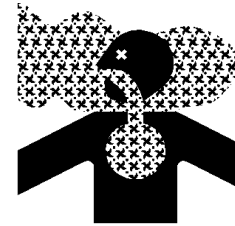

PC002



DANGER

Handling battery

- Keep flames away from battery.
- Battery may generate hydrogen gas and may explode.
- Battery electrolyte is dilute sulfuric acid.
In case of mishandling, it could cause skin burning.
- Wear protective gloves and safety glasses when handling a battery.
- Dispose of battery, observing local regulations.



D004



TR0093

1.Safety

WARNING

Safety outfit

- When handling machine, do not wear;
 - loose clothes
 - clothes with unbuttoned sleeves
 - hanging tie or scarf
 - dangling jewelry
- Such outfit could be caught in the machine or dragged in the rotating portion of the machine, and could cause a serious injury.

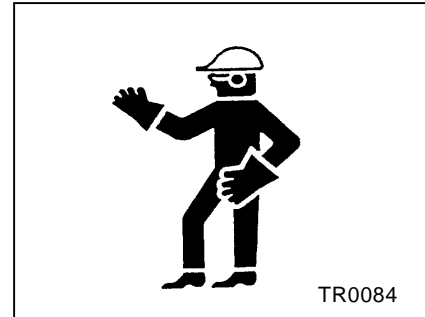

WARNING

Maintain both physical and mental health

- Do not operate the machine when you are tired or drunk or under the influence of drugs. Otherwise, a hasty conclusion or careless handling may cause unexpected injury or accident. Manage your physical and mental health and be cautious in handling the machine.

CAUTION

Protection equipments

- Please wear protection implements, such as a helmet, protection glasses, earplugs, safety shoes, a glove, and a protection-against-dust mask, according to the contents of work for safety.

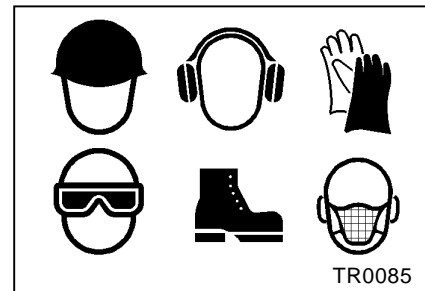

CAUTION

Safety fittings

- Have first-aid boxes and fire-extinguishers near the unit ready for emergency situations such as injuries and a fire.
- It is advisable to have a list of phone numbers of doctors, ambulance and the fire department available in case of emergency.

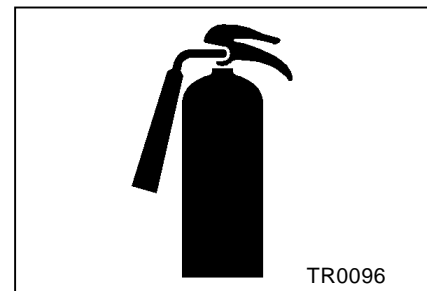

CAUTION

Safety around the machine

- Such things as unnecessary equipment and tools, cables, hoods, canvas sheets and pieces of wood which are a hindrance to the job, have to be cleared and removed. This is because operators and personnel nearby may stumble on them and may be injured.

1.Safety

1.2 Caution during Operation



Never touch the output terminals and interior of control board

- Never touch the output terminals during operation.
- Notice that the voltage of several hundreds volt is applied to the output terminal.
- When removing or connecting a connecting cable for changing load, be sure to switch OFF the circuit breaker, remove the starter key from the starter switch, then carry out a work. The operator must keep the key during operation.
Neglecting the cautions mentioned above, and a third party starting the machine during operation may cause serious accidents such as electric shock.

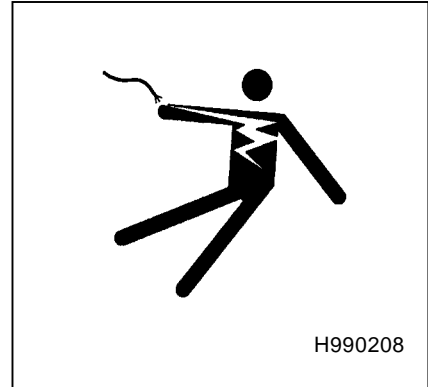

Hands off from rotating parts and belts

- Keep hands off from the rotating portion or belts while running. It could cause serious injuries if hands should be caught in.

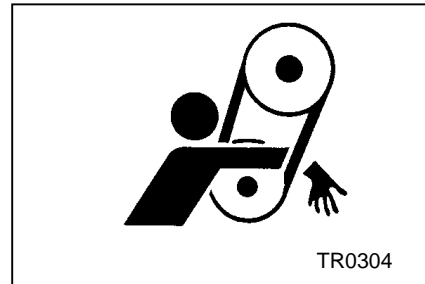

Do not remove radiator cap during operation

- Do not, under any circumstance, open the radiator cap while running or immediately after stopping operation. Otherwise high temperature steam jets out and this could cause scalding.

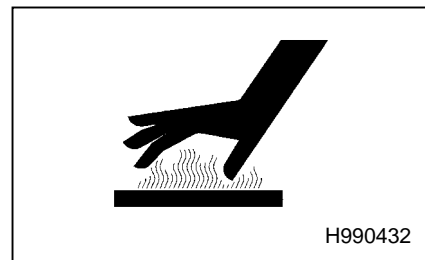

1.Safety

CAUTION

Do not touch hot parts

- Never work nearby hot portions of the machine while it is running.
- Do not touch hot portions of the machine while inspecting the machine when running.
- Such parts as engine, exhaust manifold, exhaust pipe, muffler, and radiator are especially hot, so never touch those parts, because it could cause scalding.
- Coolant water and engine oil are also very hot and dangerous to touch. Avoid checking or refilling them while the unit is running.



H990432

CAUTION

Fire prevention

- Do not, under any circumstance, bring lit cigarettes or matches near such oils as diesel fuel oil, and engine oil, etc. They are extremely flammable and dangerous, so be careful when handling.
- Refilling oils should be done in an outdoor well-ventilated place.
- Refuel after stopping the engine, and never leave the fuel nearby the machine. Do not spill. It may cause a fire. When it is spilt, wipe it up completely.
- Such parts as muffler and exhaust pipe can be extremely hot. Remove twigs, dried leaves, dried grass and waste paper, etc. from the exhaust outlet of the muffler.
- Keep a fire extinguisher available by the machine in case of unexpected fire.



D004



H990433

1.Safety

1.3 Cautions during Inspection and Maintenance



WARNING

Hang a "Now Checking and under Maintenance" tag

- Before starting inspection, switch off the circuit breaker of this machine, remove the starter key from the starter switch, and then hang a "Now Checking and under Maintenance" tag where it can be easily seen. The checker must keep the key during checking and maintenance.
- Remove the negative (-) side cable from the battery.
If the above procedure is neglected, and another person starts operating the machine during check or maintenance, it could cause serious injury.

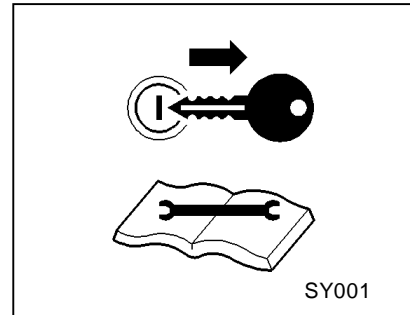

WARNING

Adjusting tension of fan belt

- Be sure to stop the engine and remove the starter key whenever the tension of the fan belt is to be adjusted.
- If the machine is running, it might catch the operator's hand into the fan belts, and this could cause a serious injury.

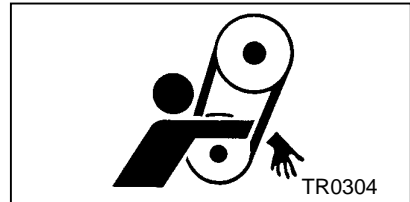

WARNING

Hands off from cooling fan

- Be sure to stop the engine and remove the starter key whenever check or maintenance work is carried out near the cooling fan.
- If the cooling fan is rotating, it may catch the operator or part of his body into the fan, and it could cause a serious injury.

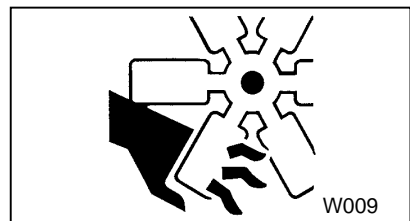

WARNING

Cleaning by air-blow

- When cleaning dust accumulated in such devices as the air-filter, etc., by blowing compressed air, wear safety glasses, etc. to protect your eyes.



CAUTION

Lighting apparatus

- It is recommended to use a lamp with safety guard fitted where the site is dark. Operating the machine gropingly or by relying on one's intuition could cause unexpected accidents.
- Any lamps without safety guard are not recommended since they can be broken and they could ignite flammables such as fuel, etc.

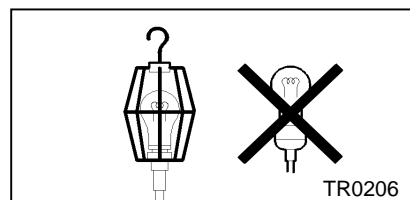

1.Safety

CAUTION

Opening coolant water drain valve

- Be sure to stop the engine, and let the coolant water sufficiently cool down before draining it.
- If the drain valve is opened before the coolant water is cooled enough, hot water could jet out, and it could cause scalding.

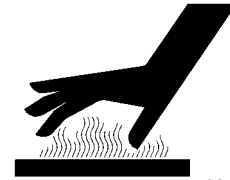

H990432

CAUTION

Refilling or draining of engine oil

- After stopping the engine, wait 10 to 20 minutes until the engine oil cools off. Then check the level of the engine oil, or refill or drain the oil.
- During operation or immediately after the engine stops, its oil is extremely hot and pressurized, so it may jet out when the cap is loosened. Be careful not to scald yourself from it.

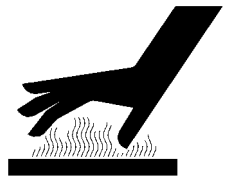

H990432

CAUTION

Cleaning the unit

- When washing the machine, cover the control panel, generator and its electric parts to prevent them from being exposed to splashing water and avoid possible decrease in electrical insulation or other troubles to the machine.

CAUTION

Disposal of waste liquid, etc.

- Waste liquid from the machine contains harmful material. Do not discharge it onto the ground or into the river, lake or sea. Such material will pollute the environment.
- Be sure to use a container to hold the waste liquid from the machine.
- Be sure to follow the designated regulations when disposing of oil, fuel, coolant (antifreeze), filter, battery or other harmful materials.

1.Safety

1.4 Safety Warning Labels

Following labels are attached to the machine.

Keep them clean at all times. If they are damaged or missing, immediately place an order with your nearest dealer for replacement. Part numbers are indicated on the lower right corner of the label.

Adhere a new one to the original location.

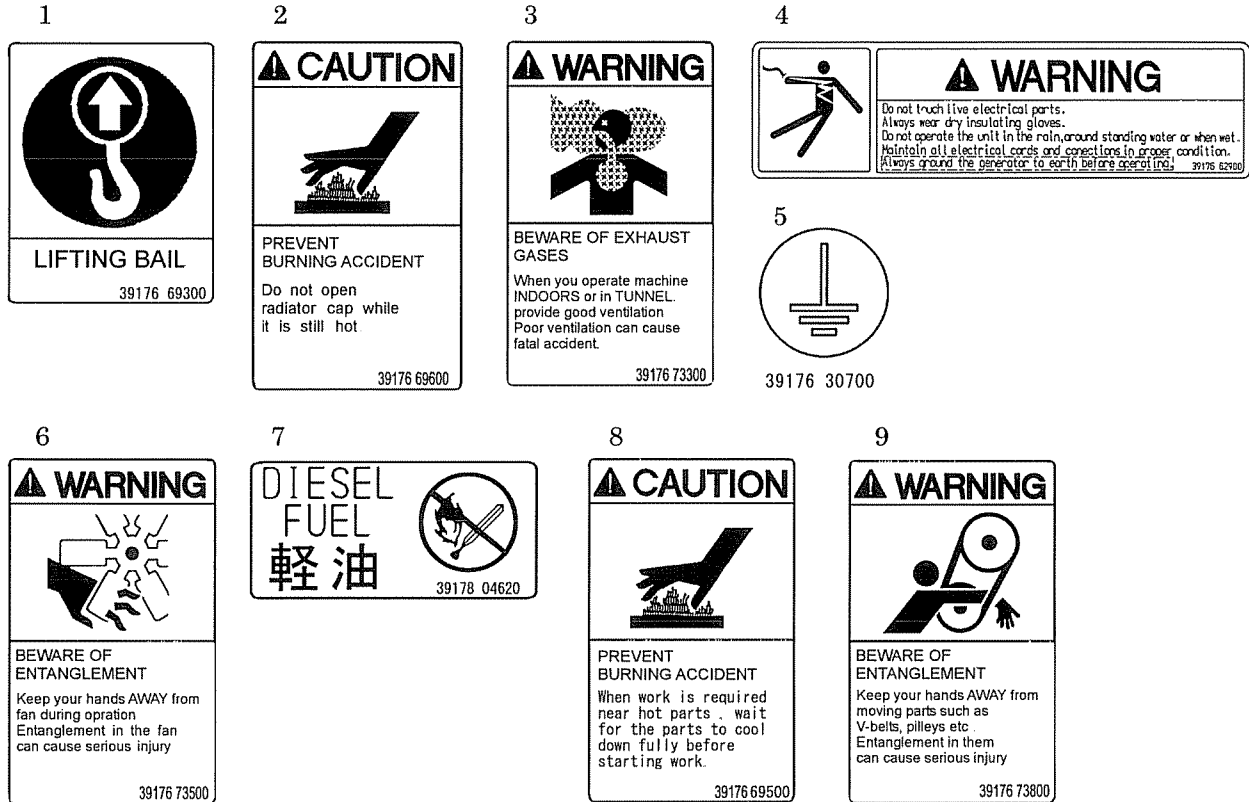

● The pasting position of safe warning label is as follows.

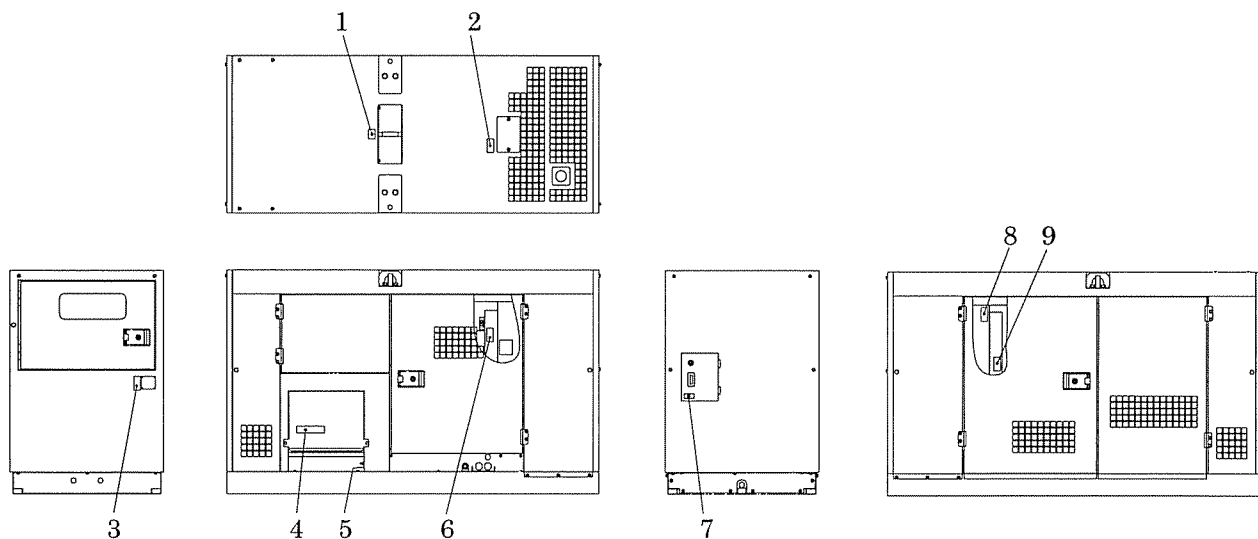

A050542E

2. Part Names

2.1 Unit Appearance and Part Names

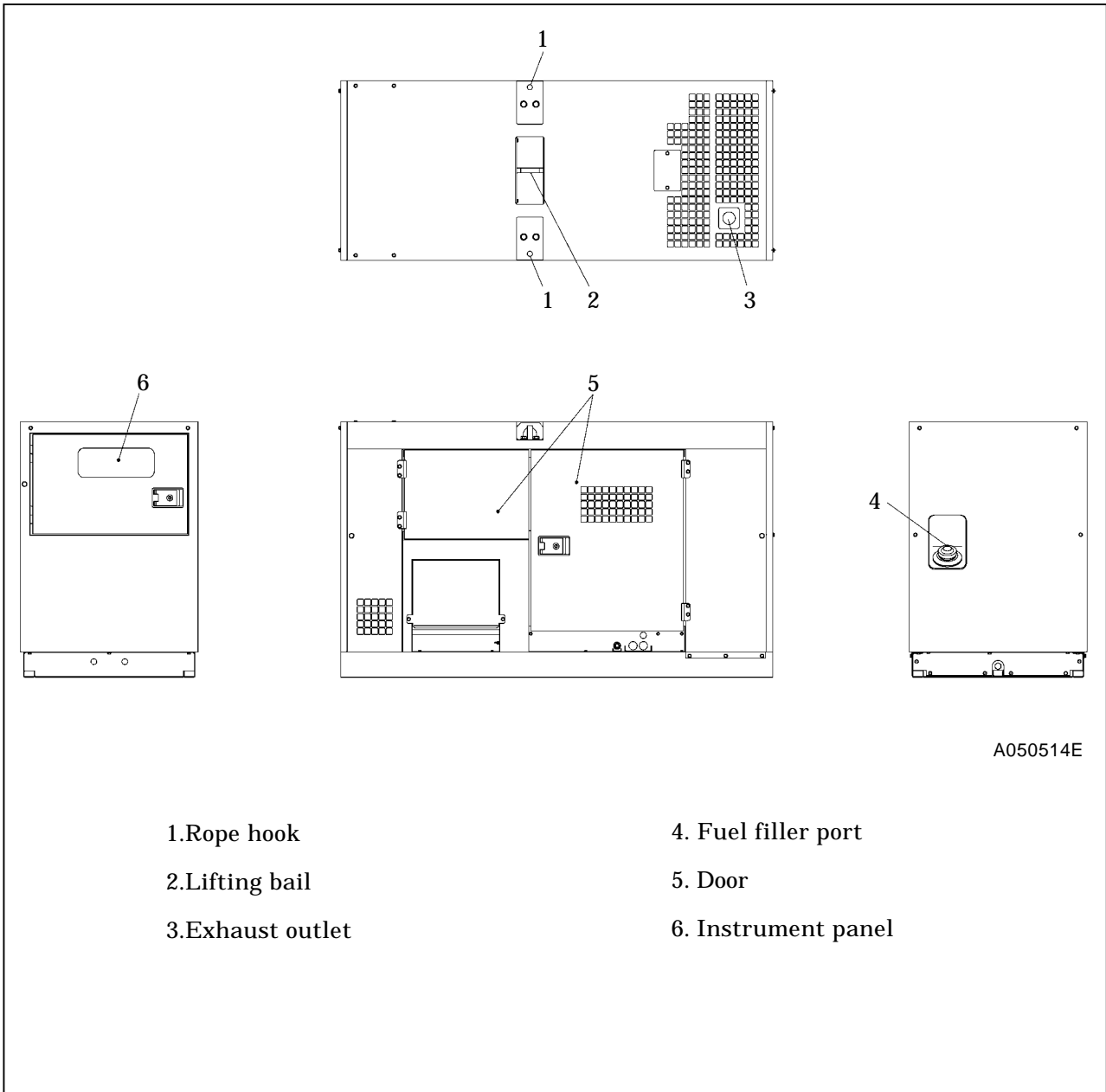

A050514E

1.Rope hook

2.Lifting bail

3.Exhaust outlet

4. Fuel filler port

5. Door

6. Instrument panel

2. Part Names

2.2 Internal Components

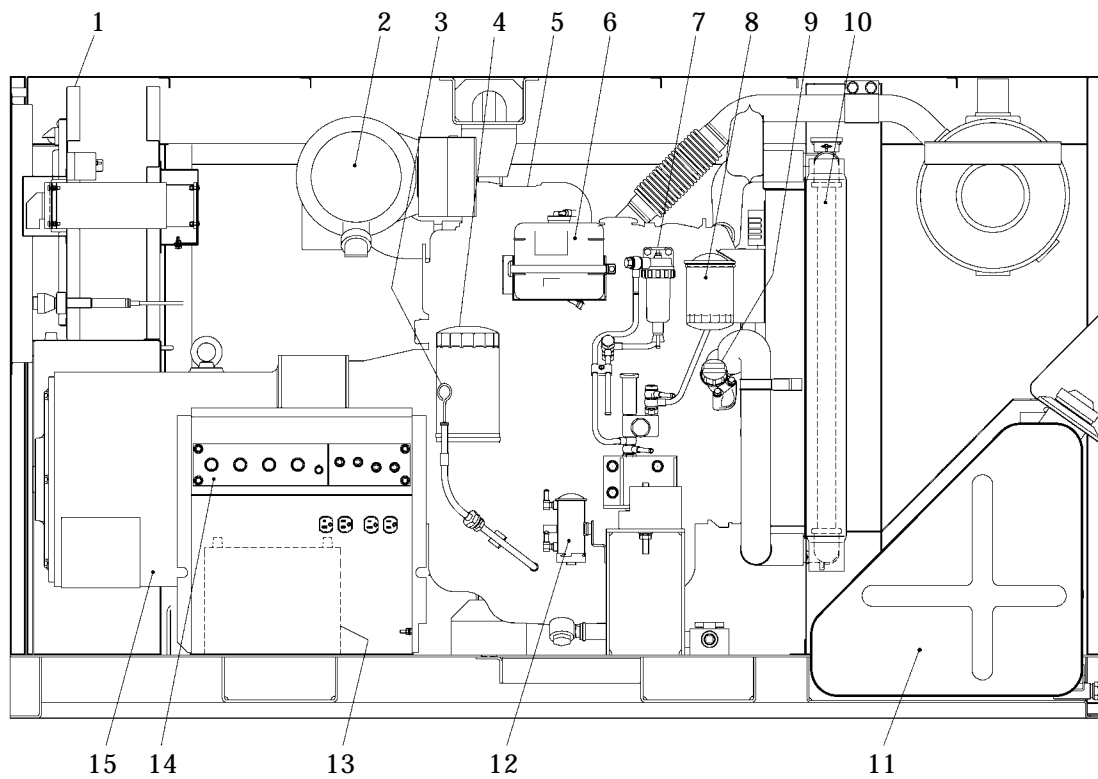

A050555

- | | |
|---------------------------|--|
| 1. Control panel | 9. Engine oil filler port |
| 2. Air filter | 10. Radiator |
| 3. Engine oil level gauge | 11. Fuel tank |
| 4. Engine oil filter | 12. Fuel air-bleeding electromagnetic pump |
| 5. Engine | 13. Battery |
| 6. Reserve tank | 14. Output terminals |
| 7. Sedimentor | 15. Generator main unit |
| 8. Fuel filter | |

3. Installation

3.1 Transporting Unit



Transportation

- Use the lifting bail “1” at the center of bonnet for hoisting up and down the machine.
Since the rope hook is not strong enough to be used for hoisting, never use it to prevent falling accident.
- When transporting the machine, be sure to put it on the truck bed and use the rope hooks “2” to secure it with rope
- Do not hoist up the machine while it is running. Otherwise, a fatal trouble or serious accident may occur.

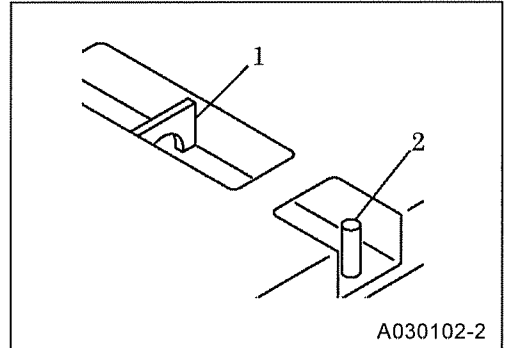

3.1.1 Lifting

- Use the lifting bail “1” fitted on center of bonnet.
- Select an appropriate crane or truck by referring to the mass and dimensions mentioned in “Specifications”.
- Only a qualified crane operator is allowed to operate a crane.

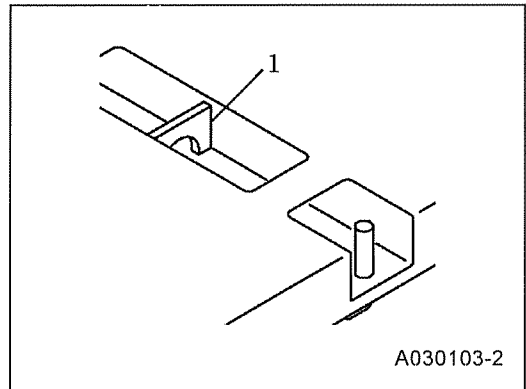

3.1.2 Securing a machine on truck bed when transporting

- When moving or transporting a machine from site, place it on truck bed and fasten it by ropes “3” at two hooks “2” on both right and left sides and 4 points on the common frame.

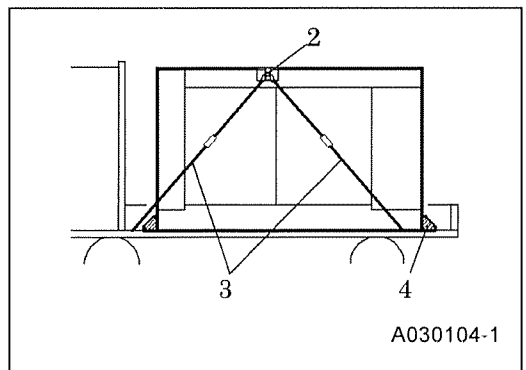

3. Installation

3.2 Place and Conditions of Unit Installation

WARNING

Ventilation

- Exhaust gas from the engine is poisonous, and it could cause casualties when it is inhaled.
Avoid using the machine in an insufficiently ventilated building or a tunnel. When the machine is unavoidably used in such insufficiently ventilated place, ventilation devices and ventilation pipe should be provided for better ventilation.

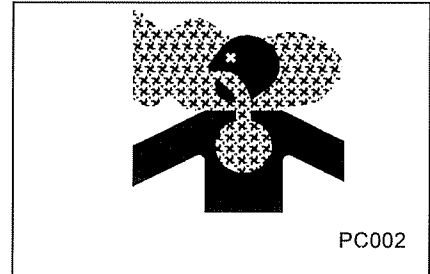

WARNING

In case that the unit is installed indoors

- In case that the unit is installed indoors for operation, suction air port and exhaust fume outlet port should be provided for better air ventilation.
- Make sure to secure enough space in front of air suction port and also to secure it after exhaust fume outlet port so that the engine may not get overheated.
- Exhaust fume pipe extension should be provided to send exhaust fume out of the installation place.

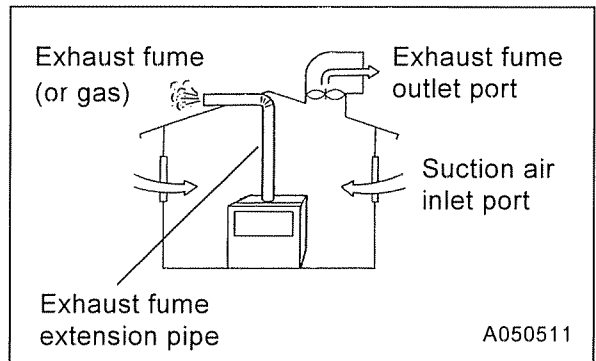

WARNING

Installing the unit in such poorly-ventilated place

- In case that the unit is installed inside any tunnel, make sure to provide fresh air and ventilate it.
- In this case, make sure to extend the exhaust fume pipe outdoors, and also make sure to prevent any leak from any connection pipes. In case that the unit is operated under exhaust air pressure, make sure to install the exhaust pipe to be supported.

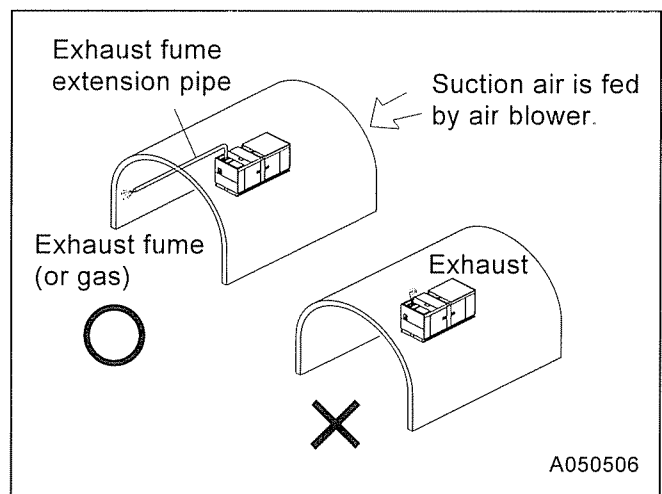

3. Installation

WARNING

How to locate the unit

- Never locate the unit with the exhaust muffler facing any private house:
- As the exhaust fume (gas) from the engine is poisonous, never direct it to any other persons passing by.

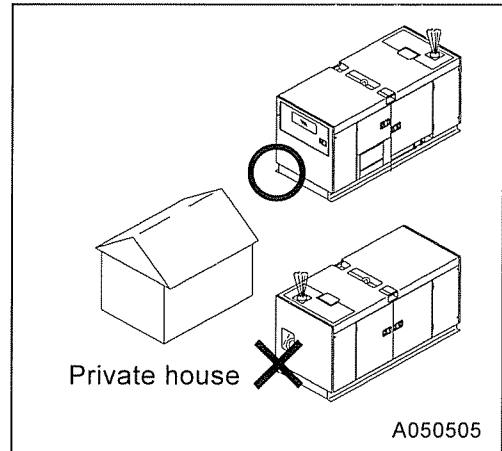

WARNING

Installation

- The machine has to be installed on dry, firm, and level area.
- The machine should be installed within 5° degree inclination.
- Avoid installing the machine in a place such as a damp place or a place where puddles are apt to be formed after rain. Such installation could cause electric shock.
- When installing the machine at the sea shore or on a ship, make sure that the machine should not be exposed directly to sea water.
- When installing the machine at a sandy place, make sure that exhaust from the generator or radiator does not blow the sand up in the air, or into the machine.
- In case that the unit has to be installed inevitably on any rough and uneven ground; it is necessary to insert square wooden bars under the unit for levelling it.

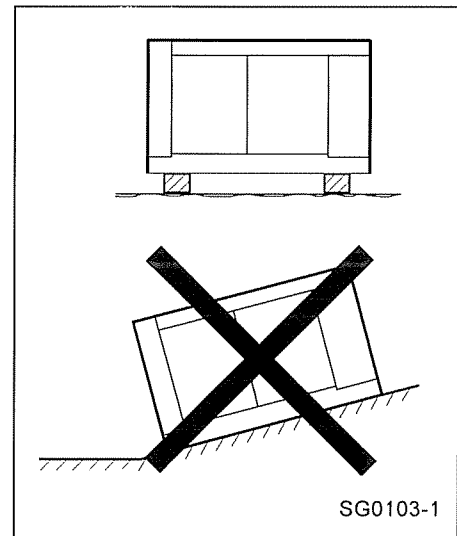

- The machine should be operated in following conditions:
- Ambient temperature — —15°C to +40°C
- Humidity ————— Less than 85%
- Altitude ————— Lower than 500 m above sea level
- If more than two machines are placed parallel in operation, keep enough distance so that exhaust air from one machine does not effect the other one.
- Keep enough space around the machine for inspection and maintenance access.

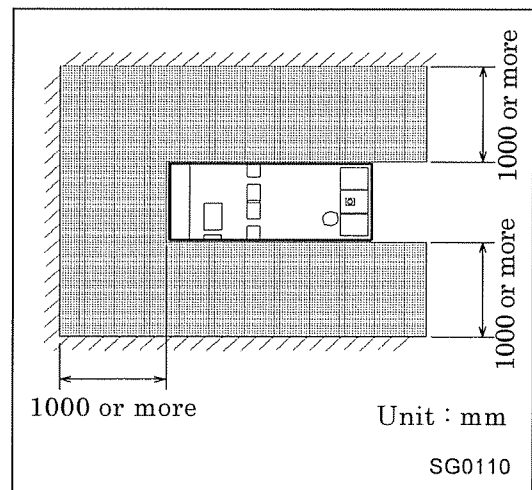

3. Installation

CAUTION

- In order to prevent from entering the jobsite or touching the equipment any other persons than the persons engaged in the job, please prepare for safety fences around the unit:

Preparation of safety fences

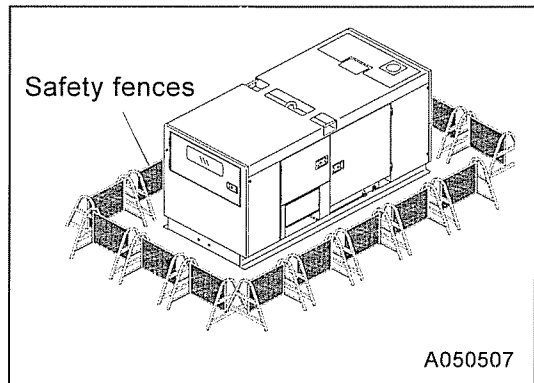

3. Installation

3.3 Leakage Protection Device and Grounding Method



Caution on Grounding

- Make sure to perform grounding connection of the external body of load. If such grounding connection is neglected or fails, it can cause electric shock to human body by leaked current, leading to serious accident as death.
- Grounding terminal for residual current relay and grounding terminal of the package of the machine can be connected to both independent grounding base and to common grounding base. However, the grounding terminal of the package(external face) of load should be connected independent of the other connections.
- The leakage relay does not work about the leak between two wires.

3.3.1 Leakage Protection Device

- This machine is equipped with a leakage relay which detects leakage caused by a defective insulation of working load to prevent an accident such as an electric shock by shutting down the circuit. However, for additional safety, install ground fault circuit interrupter (GFCI) for each load equipment close to the load equipment. The sensitivity current of the leakage relay is 30 mA.

3.3.2 Grounding Method

<Procedure>

- Connect a lead wire fitted with a ground rod to the leakage relay grounding terminal (E) of the three-phase output terminal board.
Connect the generator machine ground terminal of the package to ground.
Be sure to ground the package of the load equipment as well.
These grounding must be carried out in accordance with local regulations.

3. Installation

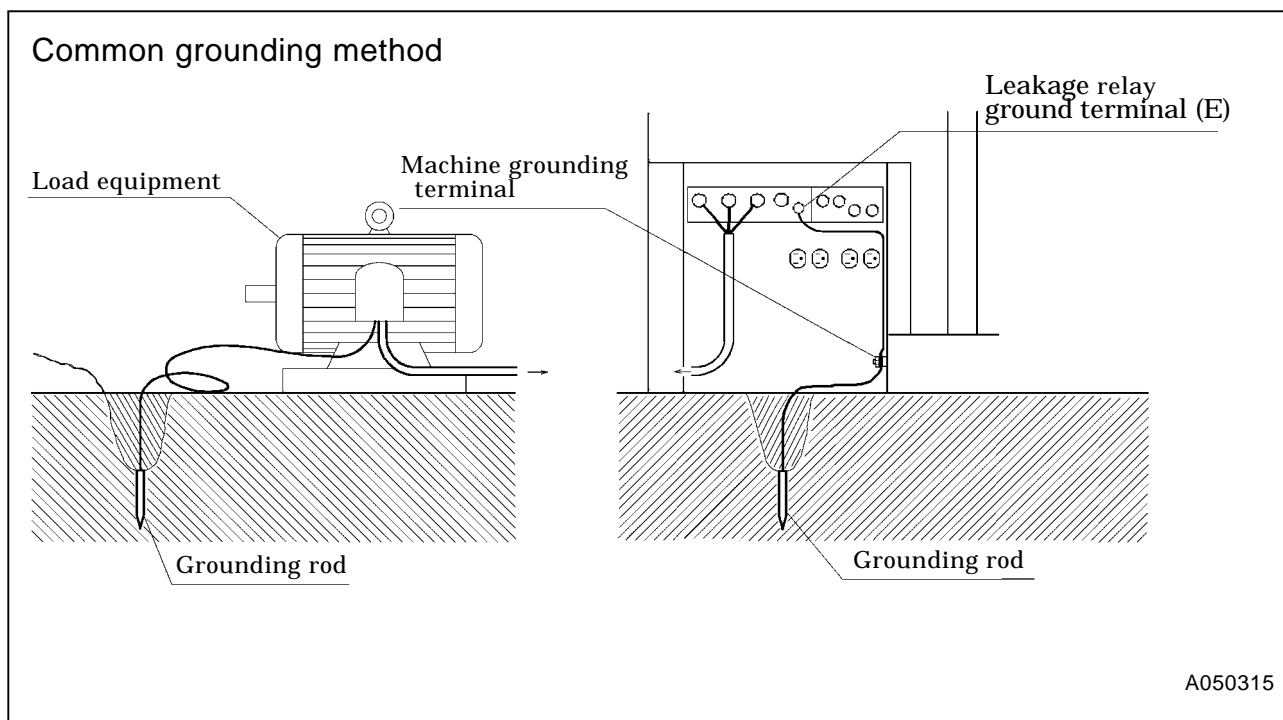
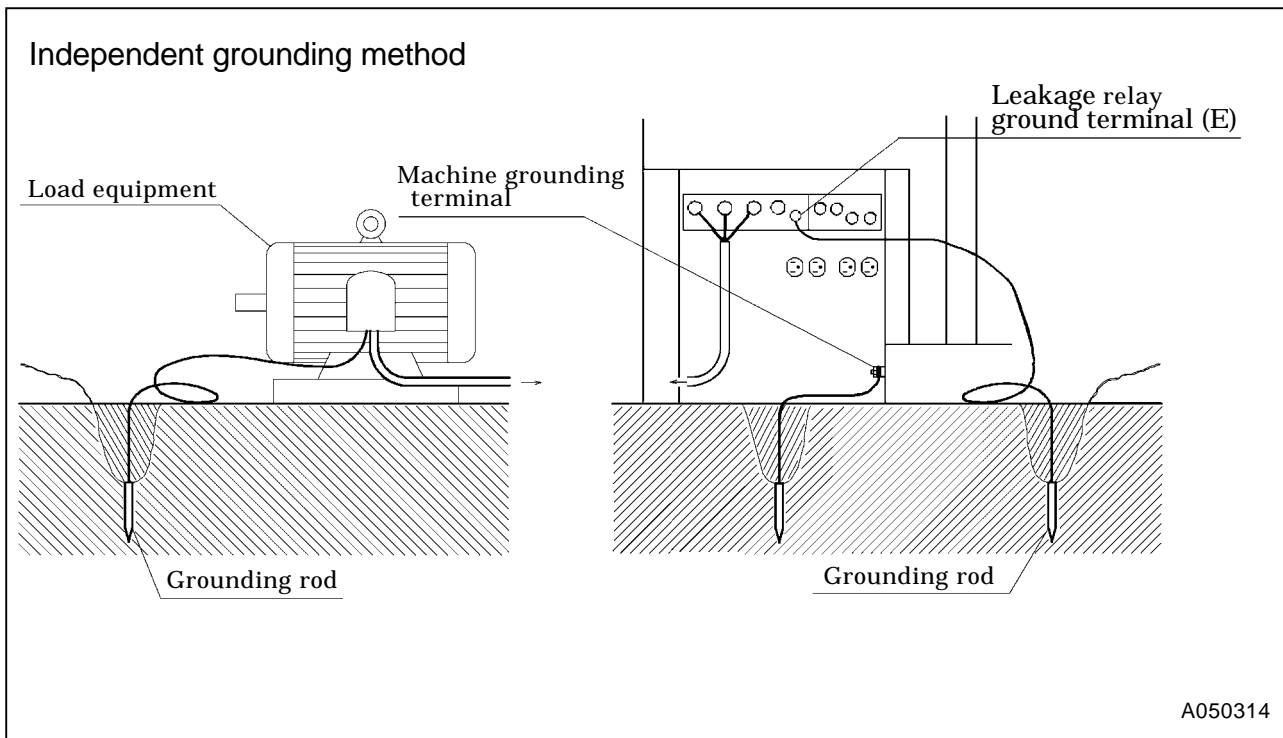

3. Installation

3.4 Selecting Cable

- Select a cable with sufficient diameter by considering the permissible current on the cable and the distance from the machine to the load.
- If the current flowing to the load exceeds the permissible current of the cable, resultant overheating may burn the cable. Similarly, if the cable is too small in thickness to the length, the input voltage to the load will fall to cause the load input power to drop, as a result, the performance of the machine cannot be displayed.

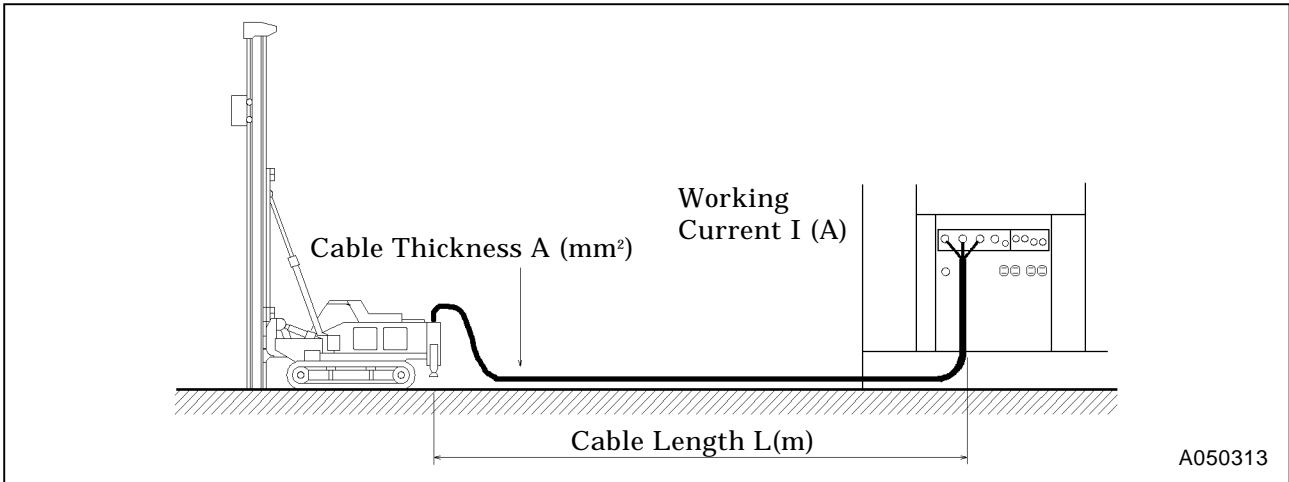

- Simplified three-phase three-wire formula to seek voltage drop from cable length and working current. Select such a cable length and thickness so that the voltage drop will remain less than 5%.

Output system	Voltage drop	
Single-phase 2-wire Type	$e = \frac{35.6 \times L \times I}{1,000 \times A}$	e : Voltage drop(V) e' : Voltage drop between an outside line or one line of each phase, and a neutral line (V) A : Cable thickness (mm ²) L : Cable length (m) I : Working current (A)
Three-phase 3-wire Type	$e = \frac{30.8 \times L \times I}{1,000 \times A}$	
Single-phase 3-wire Type and Three-phase 4-wire Type	$e = \frac{17.8 \times L \times I}{1,000 \times A}$	

- The following tables show the relations between the cable length and the cable thickness (nominal cross-sectional area) suited to the working current.

(Based on the condition that working voltage is 200 V, with voltage drop of 10 V.)

Single-Conductor Cable

Unit:mm²

Length Current	50m	75m	100m	125m	150m	200m
50A	8	14	22	22	30	38
100A	22	30	38	50	50	60
150A	38	38	50	60	80	100

Three-Conductor Cable

Unit:mm²

Length Current	50m	75m	100m	125m	150m	200m
50A	14	14	22	22	30	38
100A	38	38	38	50	50	60
150A	22 × 2	22 × 2	38 × 2	38 × 2	38 × 2	50 × 2

3. Installation

3.5 Selector Valve of Fuel Pipe

CAUTION

- In order to use a separator fuel storage tank, be sure to change the handles of the selector valves to a predetermined position. If you make a mistake in turning the handles, it can burst the fuel pipe and cause overflowing. It could lead to a serious accident.

3.5.1 Selector valve

The valve is designed to supply fuel oil directly from a separate storage fuel tank provided outside the machine, using the selector valves as shown in the following figures.

3.5.2 Operation method

Unit is delivered from factory with fuel line piping and selector valves built in as shown in the following Fig.1. When operating a unit, using installed fuel tank, run the machine with the fuel line piping and the handles of selector valves factory-arranged.

When using a separate storage tank, remove the plug fitted at the connections to the separator tank and make piping as shown in Fig.2. And then turn the handles of the selector valve as shown in Fig.2.

When removing the piping connections, make sure to return the handles to the original positions shown in Fig.1 and install the plugs.

3.5.3 Installation of Separate Storage Fuel tank and piping method

Use oil resistant hoses of inside diameter of 8mm to 10mm.

Install the fuel tank so that the fuel level of the tank may be kept at the level from zero to 2.5m high from the machine installation level.

In order to avoid suction of water and sediment together, install the suction pipe so that the inlet port of suction pipe may be kept at the 15mm to 20mm higher level than the bottom line of the tank. Also install the outlet port of the return pipe inside the tank. (see Fig.2 · A)

When refilling fuel in the tank, take much care not mix water and sediment.

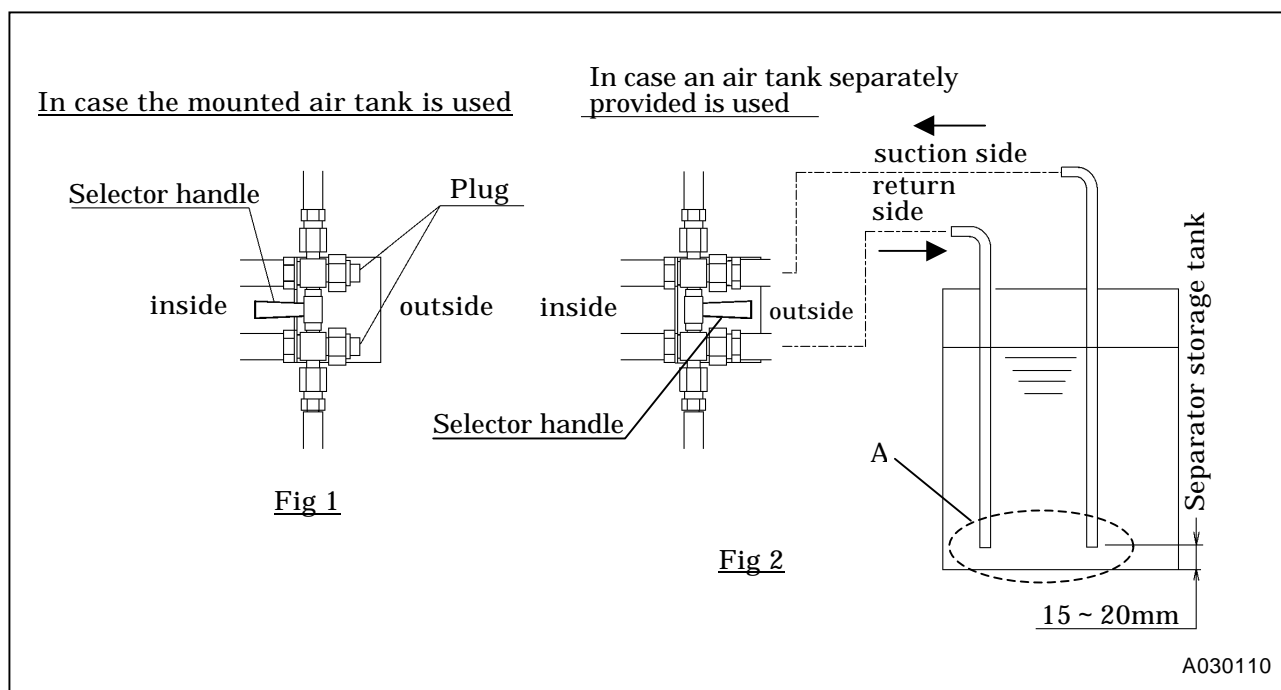

4. Operation

4.1 Instrument panel

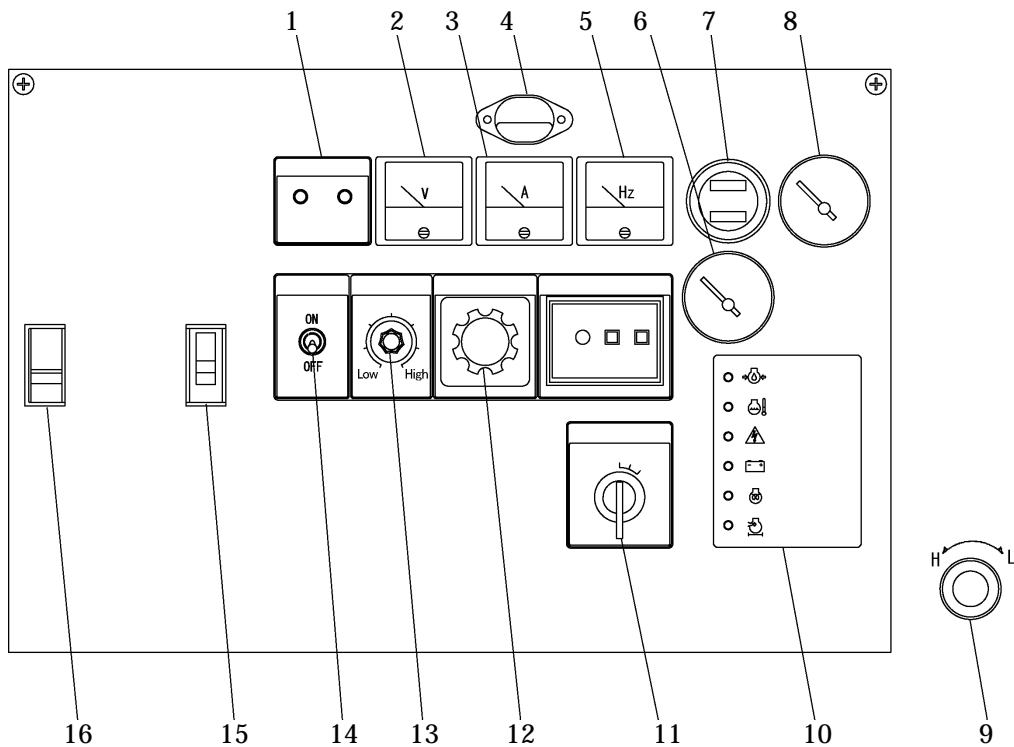

A050531-1E

- | | |
|-----------------------------|--|
| 1. Output indicator lamp | 10. Monitor lamp (for details, see 4.2.1) |
| 2. Voltmeter | 11. Starter switch |
| 3. Ammeter | 12. Current selection switch |
| 4. Panel light switch | 13. Voltage regulator |
| 5. Frequency meter | 14. Panel light switch |
| 6. Oil pressure gauge | 15. Circuit breaker |
| 7. Fuelmeter with hourmeter | 16. Circuit breaker(dedicated to single phase) |
| 8. Water temperature gauge | |
| 9. Speed control knob | |

4. Operation

4.2 Protection device







WARNING

- For prevention of troubles during operation, this machine is provided with various protection devices. When the engine stops due to function of the protection devices and circuit breaker trips, get rid of the causes of trouble, referring to the trouble shooting clause and then restart operation.

4.2.1 List of protection devices

- This machine is equipped with the following devices in the table. Repair and make necessary treatment in accordance with the item ○.

Item	Engine stops	3 phase or single phase circuit breaker trips.	Lamp display	Monitor	Functions
Engine oil pressure drop	○	○	○		When engine oil pressure drops, it functions. Operating pressure: lower than 0.1MPa
Engine water temperature rises.	○	○	○		In case of abnormal rise of engine water temperature, it functions. temperature reaches 105°C
Overcurrent or short circuit	—	○	—	—	In case of overload or short circuit accident, it functions.
※Leakage current	—	○	○		In case of current leakage it functions. Sensing current: 30 mA
Discharged battery	—	—	○		It functions in case of faulty battery.
Clogging of air filter	—	—	○		When air filter is clogged and it becomes necessary to clean it, it functions.

※In order to ensure the function of ground fault circuit interruptor device, make sure to grounding connection. (See 3.3.)

4. Operation

4.2.2 Leakage Relay

- When residual current flows to machine and load, the residual current indicator lamp goes on to trip the circuit-breaker and circuit breaker(dedicated to single phase). (Set value at which it starts to function: 30mA)
- Pressing the reset button of leakage relay, and returning the lever of the circuit-breaker to OFF position once, then it is possible to switch ON the circuit-breaker again. (See 4.2.3.)

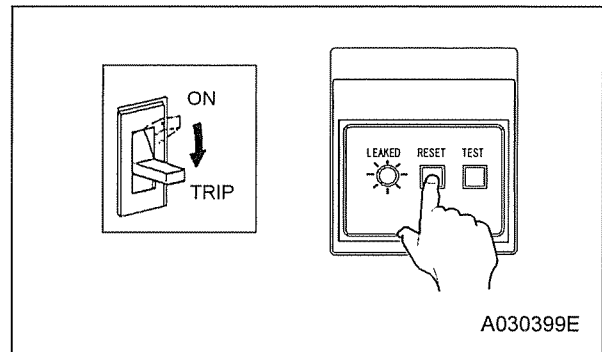

4.2.3 Circuit-breaker and circuit breaker(dedicated to single phase).

- In case overload and short-circuited wire connection should occur, the circuit-breaker trips.
- It is impossible to switch ON the circuit-breaker tripped, and so stop the engine to reset the breaker.

<How to reset>

- In order to reset the lever of circuit-breaker, press hard the lever downward till the lever sounds "click".

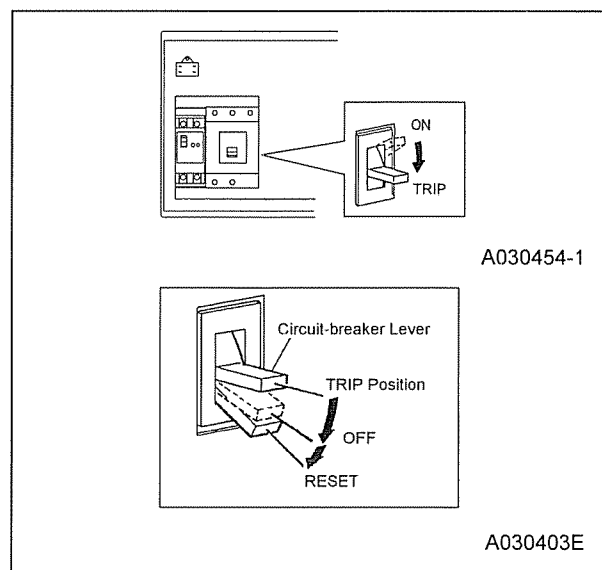

4.2.4 Thermal relay

- In case overload or short-circuit should occur to load or load connection cable, this relay functions to trip the circuit-breaker.
- It is not necessary to push the reset button even after the three phase main breaker is tripped since the thermal relay is set automatic return at factory.

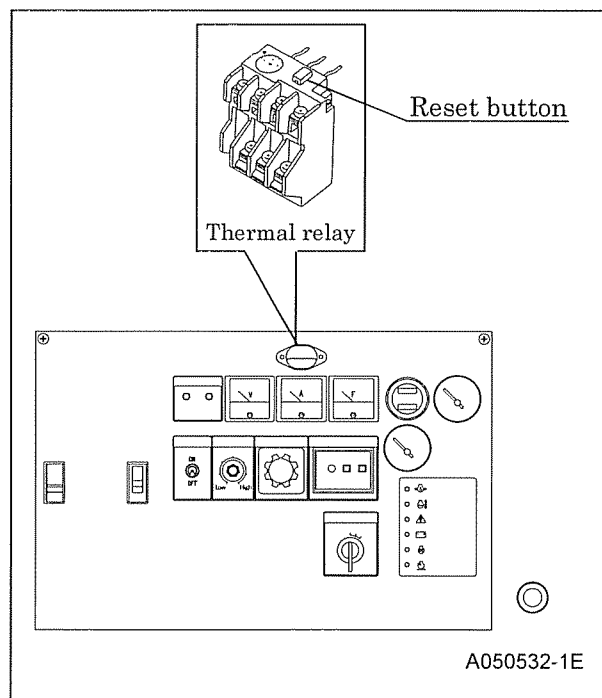

4. Operation

4.2.5 Circuit protector (CP) for AVR protection

AVR is equipped with circuit-protector (CP) for protection against overcurrent. Under the following cases, it happens to function.

- In case the machine gets overloaded while engine speed is still lower.
- In case the output voltage of machine is increased higher than the specified voltage.

<Symptom >

- When circuit protector functions and load is applied to the machine, such trouble as larger variance of voltage and/or delayed voltage recovery follow.

<How to reset >

- Press the white colored AVR button inside the control panel for resetting the circuit-breaker.

Note:Do not hold the button with such sharply pointed things as a screwdriver, ball point pens etc.

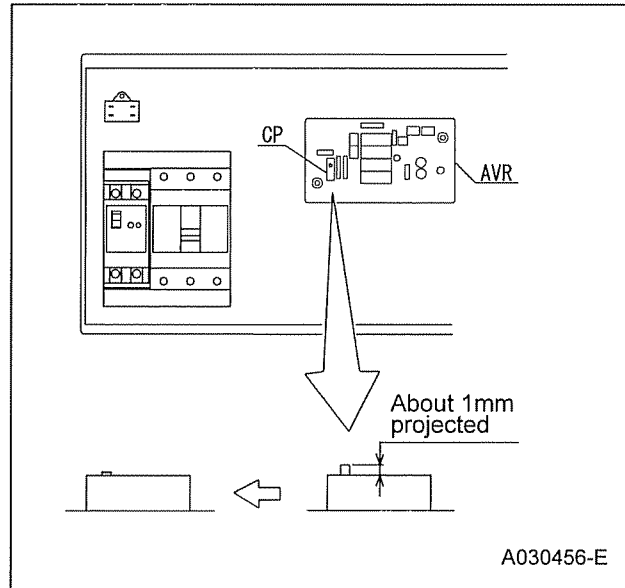

4.3 Check Frequency Selection Switch for AVR



WARNING

Do not leave control box open

- Never touch the interior of control panel during operation.
- Notice that the voltage of several hundreds volts is applied in the control panel.
- When checking or operating the interior of the control panel for changing AVR frequency, be sure to stop the machine, remove the starter key from the starter switch, then carry out a work. The checker must keep the key during inspection.

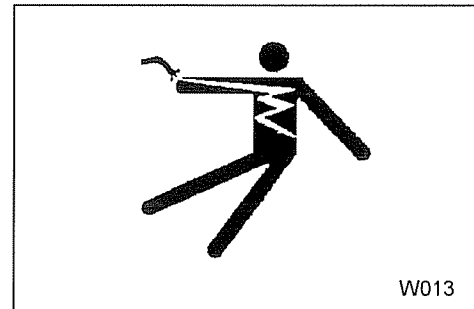

- The AVR characteristics should be changed according to the frequency.
- When changing the frequency, set the AVR frequency selection switch in the control panel to the frequency in use.
- If the frequency selection switch “1” is not set to suite the frequency in use, the rated voltage cannot be obtained.

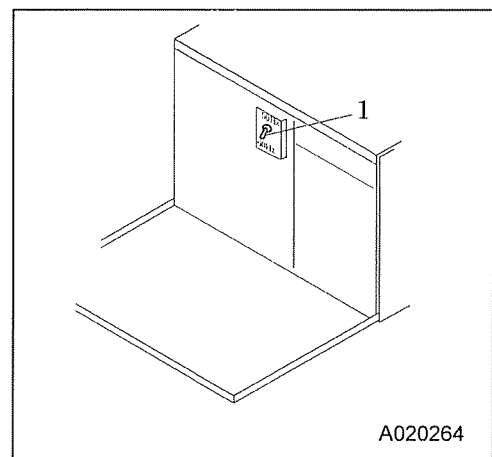

4. Operation

4.4 How To Switch Voltages

⚠ WARNING

- It is possible to select 3 phase 4 wire 200 volt or 3 phase 4 wire 400 volt. But before starting operation, make sure to confirm the voltage set for the machine without fail. If any load is connected to the machine with the wrong voltage set, it can cause damage or burning accident to the load.
- When switching the voltages, make sure to stop the machine.
- Open the operation panel on the control panel, and switch the voltages by connecting of short-circuit plate "1" as shown in the following figure.

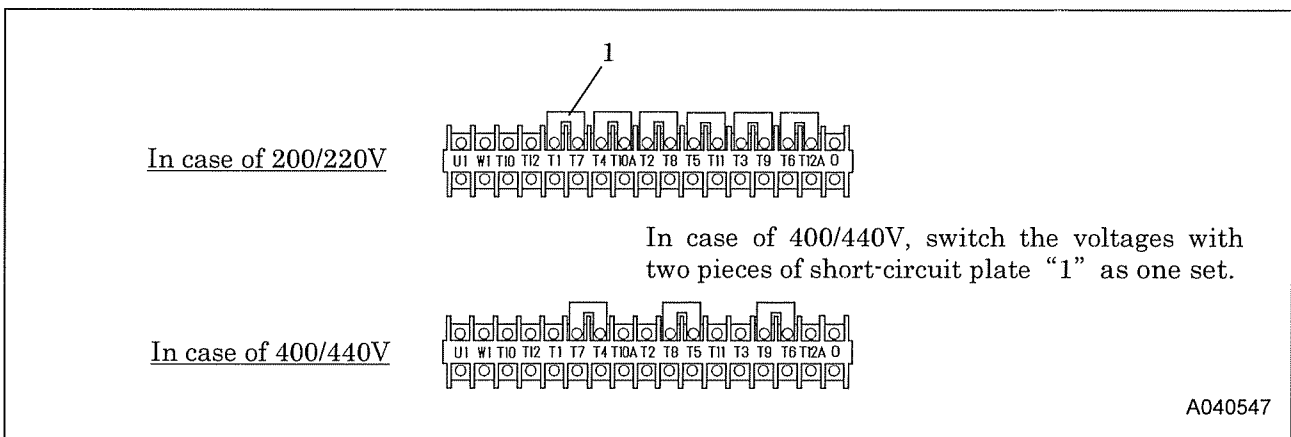

- When you start operation, the lamp of your selected voltage goes on. So make sure to check whether the lamp goes on correctly to your selected voltage.

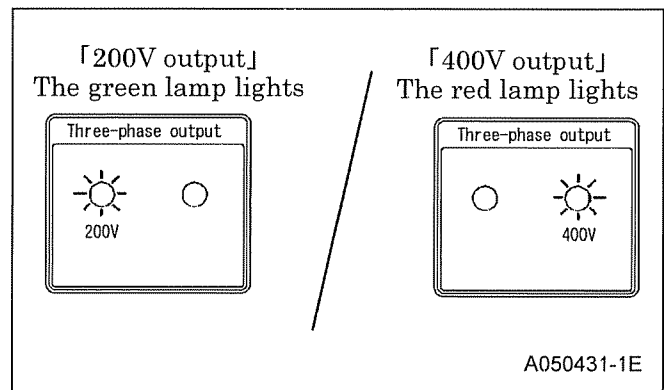

4. Operation

4.5 Connecting Load

⚠ WARNING

Electric shock and electric leak

- Make sure not to connect the output terminal of the machine with the commercial power source from electric power company. This is not only prohibited by the regulations, but it may cause an electric shock, machine troubles and even a fire.
- Make sure to ground the machine and the load. It could cause an electric shock when the machine is installed at a damp place or on a steel frame or a steel plate.
- Never touch the output terminals during operation.
- Notice that the voltage of several hundreds volt is applied to the output terminal.
- When removing or connecting a connecting cable for changing load, be sure to switch OFF the circuit breaker, remove the starter key from the starter switch, then carry out a work. The operator must keep the key during operation.
- For a connecting cable to load, do not use a cable with damaged sheath nor an inappropriate insulation cable to the voltage.
Secure connections between each cable terminal and input/output terminal. Otherwise, it may be slackened during operation and may cause a fire or an electric shock accident.

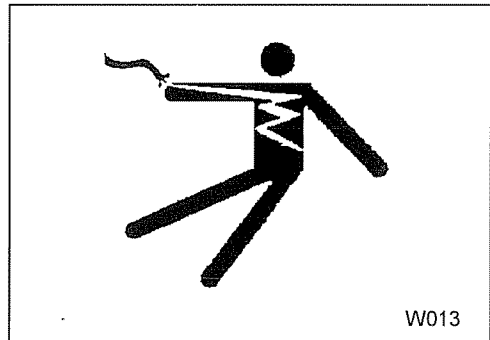
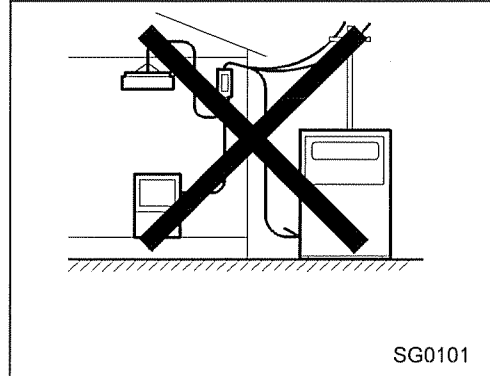

IMPORTANT

- Notice that the terminal O is not a grounding terminal of the generator. Never connect a grounding wire to it. Such connection may cause the generator main unit or the load troubles.
- When using a single-phase load [200/220V or 115/127V], see to it that the loads on the different phases will be evenly balanced. Unbalanced loads may cause the generator main unit burning.
- Select a cable with sufficient diameter by considering the load capacity and the distance from the generator to the load. Use terminals for connection and securely fasten them.
- After checking phase number and voltage of the load, make sure to connect them correctly.

—Terminal size—

Three-phase output(U,V,W,O)	: M12
Leakage relay ground terminal(E)	: M6
Single phase output (U ₁ , U ₂)	: M8
Single phase output (W ₁ , W ₂)	: M8

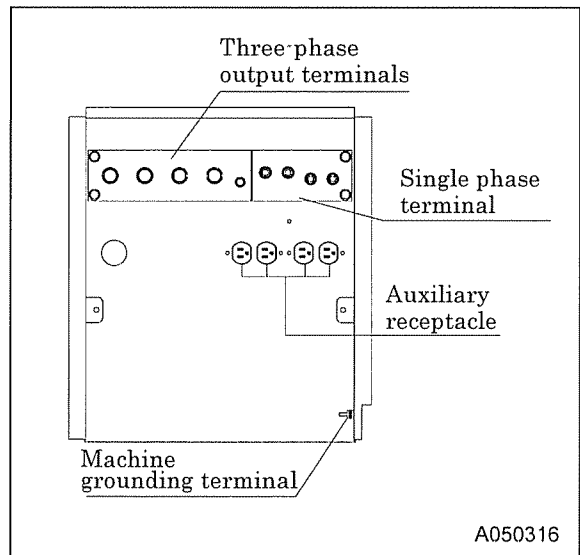

4. Operation

- Install a switch between the output terminal and the load to switch on/off the load. Do not switch the load on/off directly by the circuit-breaker of the machine.
- It could cause damage to the Connect the connecting cable to the load so that the output terminals should not touch each other. circuit-breaker.

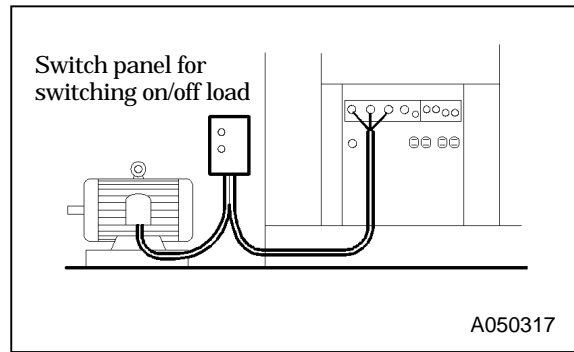

4.5.1 How to connect three phase load

- In case of three-phase load:
Adjust each current value of each phase (U.V.W) so that each value may not exceed the value in the following table. However, the values in the table are based on 80% power factor considering motor load, If the power factor is different from 80%, make sure to reduce the load accordingly to avoid overload.

Type	Permissible current value
50Hz/200V	144A
60Hz/220V	157A
50Hz/400V	72.0A
60Hz/440V	78.5A
50Hz/380V	76.0A

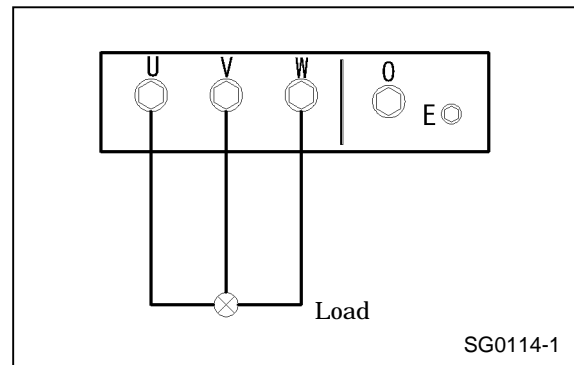

- In case inverter load:
The inverter capacity (input kVA of inverter) should not exceed the following value (within rated output \div 3.0). Also select generator so that the rated output (kVA) of generator so that the rated output (kVA) of generator may be three times of the inverter capacity.
Example: In case of SDG60S, at 50Hz, $50\text{kVA} \div 3.0 = 16.7\text{kVA}$.
50Hz: 16.7kVA (Input kVA of inverter) It is possible to use inverter capacity up to this value.
60Hz: 20.0kVA (Input kVA of inverter) It is possible to use inverter capacity up to this value.

4. Operation

4.5.2 How to connect single phase load

The method of connection of 3 phase 4 wire single phase load is as follows.

The allowable current limit shall not exceed the values in the following table.

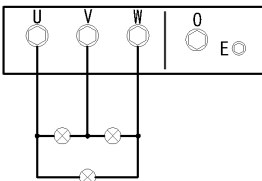
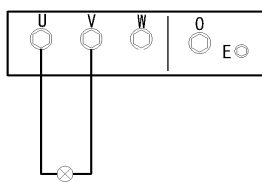
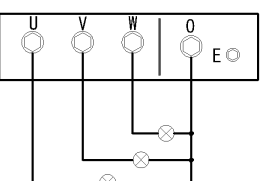
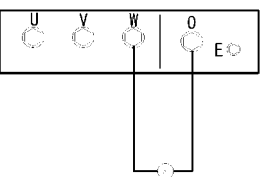
	Conditions of Load	Allowable Current Limit	Conditions												
In case of selection of 3 phase 4 wire	In case of three phases 	<table border="1" style="width: 100%; border-collapse: collapse;"> <thead> <tr> <th>Type</th> <th>Permissible current value</th> </tr> </thead> <tbody> <tr> <td>50Hz/200V</td> <td>144A</td> </tr> <tr> <td>60Hz/220V</td> <td>157A</td> </tr> <tr> <td>50Hz/400V</td> <td>72.0A</td> </tr> <tr> <td>60Hz/440V</td> <td>78.5A</td> </tr> <tr> <td>50Hz/380V</td> <td>76.0A</td> </tr> </tbody> </table>	Type	Permissible current value	50Hz/200V	144A	60Hz/220V	157A	50Hz/400V	72.0A	60Hz/440V	78.5A	50Hz/380V	76.0A	Allowable current limit up to the rated current. Adjust the load capacity so that each current value of each phase (U,V,W) may not be more unbalanced than 50%.
	Type		Permissible current value												
	50Hz/200V		144A												
	60Hz/220V		157A												
50Hz/400V	72.0A														
60Hz/440V	78.5A														
50Hz/380V	76.0A														
In case of using single phase 	Allowable current limit up to the rate current. But voltage change becomes larger due to the unbalance of each phase.														
In case of three phases 		<table border="1" style="width: 100%; border-collapse: collapse;"> <thead> <tr> <th>Type</th> <th>Permissible current value</th> </tr> </thead> <tbody> <tr> <td>50Hz/115V (200V)</td> <td>144A</td> </tr> <tr> <td>60Hz/127V (220V)</td> <td>157A</td> </tr> <tr> <td>50Hz/231V (400V)</td> <td>72.0A</td> </tr> <tr> <td>60Hz/254V (440V)</td> <td>78.5A</td> </tr> <tr> <td>50Hz/231V (380V)</td> <td>76.0A</td> </tr> </tbody> </table>	Type	Permissible current value	50Hz/115V (200V)	144A	60Hz/127V (220V)	157A	50Hz/231V (400V)	72.0A	60Hz/254V (440V)	78.5A	50Hz/231V (380V)	76.0A	Allowable current limit up to the rated current. Adjust the load capacity, so that each current value of each phase (U,V,W) may not be more unbalanced than 50%.
Type	Permissible current value														
50Hz/115V (200V)	144A														
60Hz/127V (220V)	157A														
50Hz/231V (400V)	72.0A														
60Hz/254V (440V)	78.5A														
50Hz/231V (380V)	76.0A														
In case of using single phase 	Allowable current limit up to the rated current. Bur the voltage change becomes larger due to the unbalance of each phase.														

4. Operation

4.5.3 Single Phase Output (100/110V 50/60Hz)

- In the output terminal portion the single phase output terminal (U₁-U₂) (W₁-W₂) two set and the auxiliary receptacle are provided.
- When the AC ammeter indicates 200/220V and 400/440V, the single phase output voltage is 100/110V.
- The single phase output can be used up to the rated outputs mentioned in the following table. When using the auxiliary receptacle, the total load capacity including U₁-U₂ terminal shall be used not to exceed the rated single phase output in the following table

Single phase output terminal

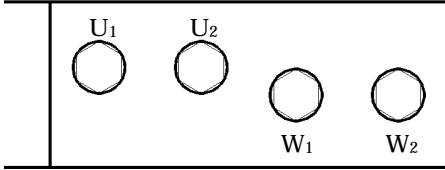

Auxiliary receptacle
(15A)

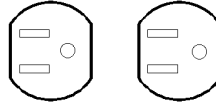

Auxiliary receptacle
(15A)

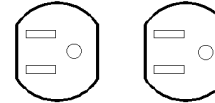

Make sure that the load capacity of W₁-W₂ shall not exceed the rated single phase output.

Make sure that the total load capacity of auxiliary receptacle and U₁-U₂ shall not exceed the rated single phase output.

A050318

(50/60Hz)

Single phase output voltage	100/110V
Rated single phase output	7.5/8.25 kVA × 2
Rated current	75/75 A × 2

- When using both single output and three phase output at the same time, the machine shall be used lower than the allowable current limit.
- Four auxiliary receptacles shall be used lower than total 15A × 2.

4. Operation

4.6 Engine Oil • Coolant • Fuel

4.6.1 Engine Oil

IMPORTANT

- Viscosity of engine oil greatly affects startability, performance, oil consumption of the engine, as well as wear of the moving parts.
- Choose appropriate oil based upon the table below according to the outside air temperature.

Relation between viscosity (SAE) and temperature

SAE Viscosity number	Temperature
10W	- 30 to 10
30	- 10 to 40
40	0 to 50
15W/40	- 20 to 40

- Be sure to use CD class engine oil or superior class. (Using engine oil with poor quality may shorten the life of the engine).
- When two or more different brands of oil are mixed, its performance can be deteriorated. Do not mix oils.
- Follow the designated regulations to dispose of engine oil.

4.6.2 Coolant

IMPORTANT

Quality of coolant and antifreeze

- Use soft water of good quality such as tap water for coolant.
- When water with dirt, sand, and/or dust contained, or hard water such as well water (ground water) is used, this will cause deposits inside radiator or on cylinder head, and will cause engine overheat due to poor flow of coolant.
- When the unit is used in a cold region and possible freezing is expected, it is recommended to use LLC (Antifreeze) for the coolant.
- Adjust mixing ratio of LLC with water according to the temperature.
- Use LLC within the range of its mixing ratio between 30 and 60%.
- If LLC in the water exceeds more than 60%, it may decrease its antifreezing effect.
(Upon delivery from the works, LLC density is 35%)

Reference of LLC mixing ratio

Temperature	Mixing ratio
- 10	30%
- 15	35%

- Follow the designated regulations to dispose of LLC (Antifreeze).

4.6.3 Fuel

IMPORTANT

Choose appropriate

- Be sure to use diesel fuel oil.
(Using other oil will cause low power output or damage the engine.)

4. Operation

4.7 Check before Starting the Machine



WARNING

Check before starting the unit

- Be sure to check the machine before operation.
When any abnormality is found, be sure to repair it before starting the unit.
- Be sure to make daily check before operation. If the unit is operated without prior check and without noticing its abnormality, such operation could cause seizure of components or may even cause fire.

4.7.1 Check Engine Oil Level

- The machine should be on level before checking oil level.
- When you check oil level after you have once started operation, wait 10 to 20 minutes after stopping engine, before checking the oil level.

< Procedure >

Pull out the engine oil level dipstick, and wipe it with a clean cloth.

Then, re-insert the dipstick fully and pull it out again. If the gauge shows the oil level between MAX and MIN limits, it is normal.

When the oil level is below its MIN, add engine oil.

(See 5.5.1.)

- While checking oil level, check also for contamination. If the oil is found dirty, contaminated, or should be changed according to the periodic inspection list, change the oil.

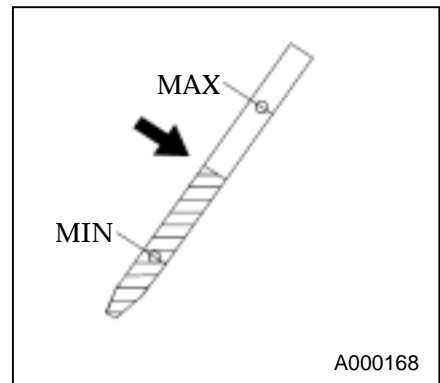

4.7.2 Check Coolant Level



CAUTION

Taking off the radiator cap

- Be sure to stop the machine first and then loosen the radiator cap slowly, after the coolant water is sufficiently cooled and the inner pressure is released.
If this procedure is neglected, its inner pressure can blow off the cap, and steam jetting out of the radiator could cause scalding.

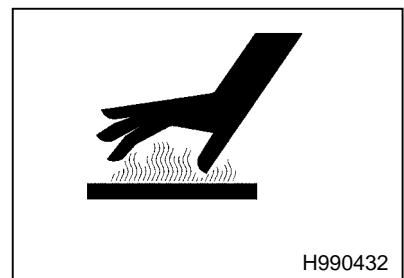

- Check the coolant level in the reserve tank. If it is lower than the limit, open the cap and replenish the coolant.
(Level must be kept above LOW mark)
- If little coolant is left in the reserve tank, replenish the tank and radiator also. (See 5.5.15.)

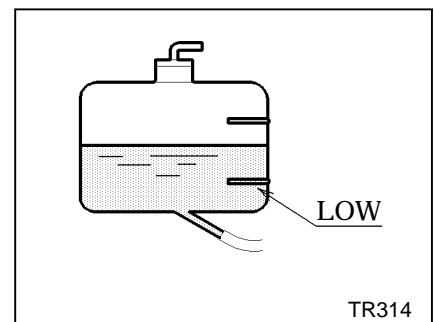

4. Operation

4.7.3 Check Fuel Level

- Check fuel level gauge before operation. Replenish enough fuel to prevent fuel shortage during operation.

CAUTION

Fire prevention

- Do not, under any circumstance, bring lit cigarettes and/or matches to the fuel.
- The fuel is extremely flammable and dangerous. Be careful of fire because it is very likely to catch fire.
- Refuel only after stopping the engine, and never leave open fuel can near the machine. Do not spill. It could cause a fire. When it is spilt, wipe it up completely.
- Refilling fuel tank should be done in an outdoor well-ventilated place.



4.7.4 Check Sedimentor

Check if the red float “ 2 ” in the water sedimentor rises up to the water drain level, then drain water if it is near the drain level “ 1 ” .

< Procedures >

Loosen the drain valve“ 4 ”to drain the water from the sedimentor. After draining the condensate, be sure to fasten the drain valve “ 4 ” .

- Removing the bowl “ 3 ” of the sedimentor shown in the right figure, fuel comes out. Removing the bowl of the sedimentor shown in the right figure, fuel comes out.
- Drain the condensate in container, and then dispose of condensate according to the designated regulations.

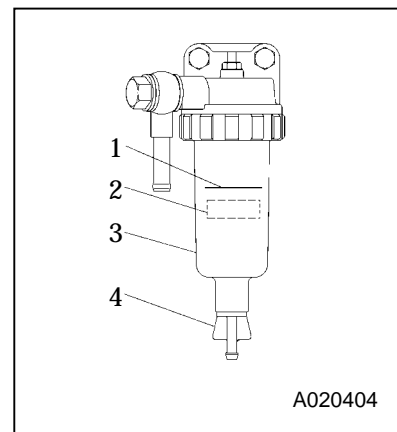

4. Operation

4.7.5 Check V-belt Tension

IMPORTANT

- If V-belt tension too tight, it can cause shaft breakage or shorten the life of a bearing. If too loose, the belt may slip and will cause early breakage or damage to the belt.

Adjust the fan belt and alternator V-belt by the following procedure:

< Procedures >

Unfasten the mounting bolts of the alternator to adjust the alternator.

Visually check the belt for any crack, wear, and other defect.

Loosen the mounting bolt of alternator once. Then adjust it so that the belt deflection will be 8-12 mm (98.1N) when pressing with a finger.

Be careful not to leave any grease and LLC on the belt. If any of such material is left, wipe it off completely.

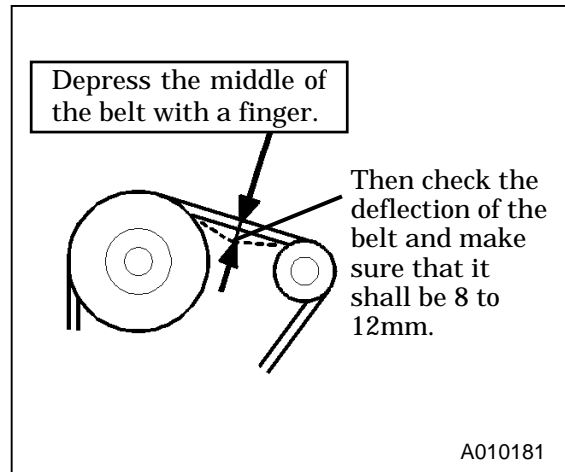

4.7.6 Check Ground of Machine Package and Leakage Relay

Make sure that the machine grounding terminal of the machine package, leakage relay grounding terminal, and the package of the load are securely grounded. (See 3.3.)

4. Operation

4.8 Operation and Stopping



Never touch the interior of output terminals ,control board

- Keep the output terminal cover shut and locked whenever the machine is running.
- Notice that the voltage of several hundreds volt is applied to the output terminal and control board.
- When opening the door unavoidably, be careful not to touch the rotating parts and hot parts. It could cause scalding and serious injury.
- When removing or connecting a connecting cable for changing load, be sure to switch OFF the circuit breaker, remove the starter key from the starter switch, then carry out a work. The operator must keep the key during operation.
Neglecting the cautions mentioned above, and a third party starting the machine during operation may cause serious accidents such as electric shock.

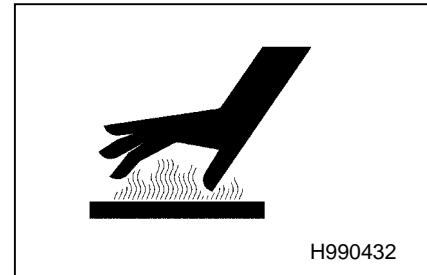
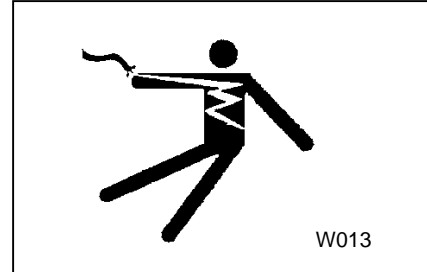

Pay caution to overload and unbalanced load

- When the breaker functions so often during operation, reduce the load.
- When using single- phase load, check the current of each phase and try to keep the load of each phase constantly average.
- If you continue to operate the generator main unit, ignoring and neglecting these cautions, it could cause burning to the unit and resulting in fire. Furthermore, should continue operation at the lower level than the standard rated frequency, it could cause burns to the generator main unit and also the motor of the load.



Draining during operation prohibited

- Do not, under any circumstance, open the portions below during operation.
- Coolant drain valve and plug
- Engine oil drain valve and plug



4. Operation

IMPORTANT

- After the engine starts up, warm up it under unload for approx. five minutes.
- Warming up after starting up is necessary for smooth operation of the engine. Do not operate the engine at full load immediately after it starts up. This will shorten the equipment life.
- During the warm-up operation, examine the different parts of the equipment for any looseness, leakage of water, oil, fuel, and other irregularities.
- Also, make sure that the alarm lamps are off.
- Be sure to operate the generator at a rated frequency, irrespective of the load capacity.
If the machine is operated with a frequency lower than the rated frequency, it could cause the generator main unit or to be burned.

4.8.1 Procedure to Start the Unit

Follow the starting procedure below.

<Start engine>

- ① Make sure that both circuit breaker (dedicated to single phase) “1” and circuit breaker “2” are “OFF” .
- ② Turn the starter switch “4” to “RUN” . Then preheating lamp “5” glows.
- ③ Immediately when the preheat lamp “5” switches off, fully turn the starter switch “4” clockwise to start engine. Engine rpm rises up to the rated rpm.
- ④ Once the engine has started up, leave the engine running to warm up for approximately five minutes.

<Check and confirm voltage and frequency>

- ① After finishing warming-up operation, check the frequency meter “9” . If the frequency is different from the rated one, adjust it, turning the speed control knob “6” .(See 4.8.2.)
- ② While watching the voltmeter “8”, turn the voltage regulator controlling “3” knob to set the voltage to the rated. .(See 4.8.2.)
- ③ Output in dicator lamp “7” is displayed in accordance with the selected output. 200V output lamp glows in green, and 400V lamp in red.

<Loaded operation>

- ① Switch circuit breaker (dedicated to single phase) “1” or circuit breaker “2” “ON”, then supply power to the load.
 - ② During operation, check and confirm whether the generator functions properly, according to the table on next page.
- ※ Before starting to supply power to the load, make sure that the voltage is in accordance with the load.

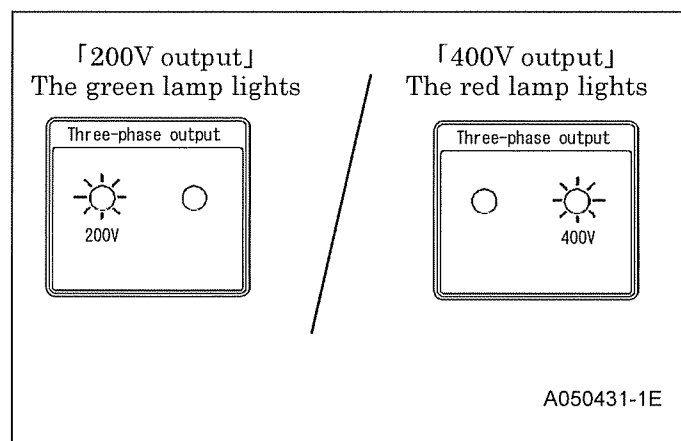
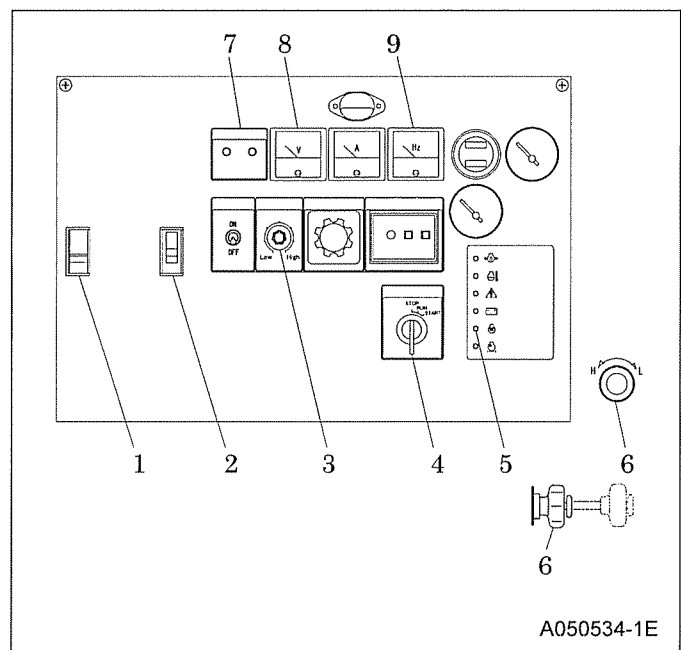

4. Operation

4.8.2 Gauge Indication while Operating

- During normal operation, each indication of instruments is shown in the table below. Refer to the table for daily checks.

		Voltmeter (V)	Frequency meter (Hz)	Ammeter (A)	Monitor lamp				
					Engine oil pressure	Water temp.	Leak	Charge	Engine Air filter
Before Starting up	Starter switch (RUN)	0	0	0	Off	Off	Off	 On	Off
		During Operation (Full load)	50Hz	200/400	50	144/72.0	Off		
60Hz	220/440	60	157/78.5						
During Operation (Unload)	50Hz	200/400	52.5	0					
	60Hz	220/440	62.5						

- Be sure to check at times to see if gauges or each component of the unit are properly working, or if there is any air-leak, oil-leak, water-leak or fuel-leak etc.
- The table above gives standard values. They may vary slightly depending on the operating conditions and other factors.
- In single-phase load operation, check the current of U, V, and W phase with the ammeter, by turning the current selection switch. When each current is unbalanced, change load connections so that the current of U, V, and W, can be equally balanced. Also make sure that the current of each phase does not exceed the rated one.

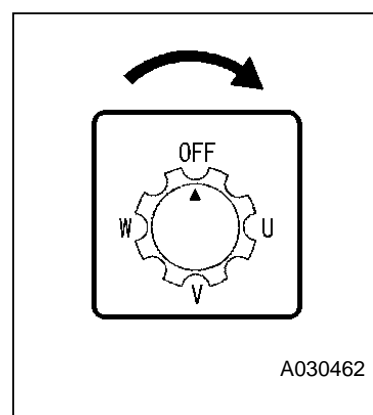

4.8.3 Panel light

- The instruments are provided with transmission type illuminators. Switch "ON" the panel light so that they may light on.
- When illumination is not necessary, turn "OFF" the light. (If the machine is always operated with the lamp switched "ON", the lamp life can be shortened.)

4.8.4 Stopping Procedures

< Procedure >

Set the circuit-breaker on the instrument panel of the machine to "OFF" position.

After about five minutes' cooling down operation, turn the starter switch to "STOP" position.

4.8.5 Operating Procedures when Engine Fails to Start up on First Attempt

- When the engine fails to start up even following the start-up procedures, do not keep the starter running, but set the starter switch back to "STOP" and wait about 30 seconds. Then, repeat the start-up procedure once again.
- If the repeated procedure does not allow the engine to run, the following causes are suspected. Therefore, check the following:
 - No fuel
 - Clogging of fuel filter
 - Clogging of filter inside the fuel air-bleeding electromagnetic pump
 - Discharge of battery (Low cranking speed)

4. Operation

4.8.6 Fuel Line Air Bleeding Device

If the unit runs out of fuel, bleed the air, according to the following procedures.

< Procedure >

Replenish fuel.

Turn the starter switch to "RUN" position.

Then the electric pump starts to automatically bleed air caught in fuel pipes.

Air bleeding will be completed within 20-30 seconds.

5. Periodic Inspection/Maintenance

5.1 Important Items at Periodic Inspection and Maintenance or after Maintenance

- The manual shows proper interval for periodic inspection and maintenance under normally operating conditions. Inspection and maintenance should be performed more often under extremely harsh conditions.

WARNING

Hang a "Now Checking and under Maintenance" tag

- Remove the starter key from the starter switch before starting inspection, and hang up a "Now Checking and under Maintenance" tag where it can be easily seen. The checker must keep the key during checking and maintenance.
- Remove the negative (-) side cable from the battery. If the above procedure is neglected, and should another person start operating the machine during check or maintenance, it could cause serious injury.
- Be sure to use appropriate tools for inspection and maintenance work. Inappropriate tools could cause unexpected injury.

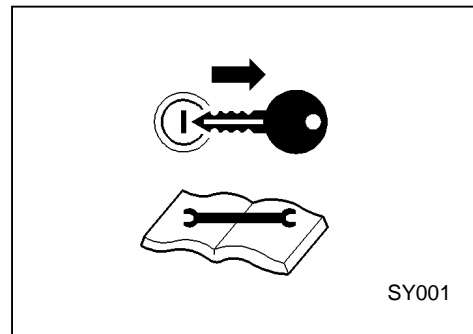

IMPORTANT

Precaution for check and maintenance

- Be sure to use recommended fuel, oil, grease, or antifreeze.
- Do not disassemble or adjust engine, compressor or part(s) for which inspection or maintenance is not referred to in this manual.
- Use genuine parts for replacement.
- Any breakdown, caused by using unapproved parts or by wrong handling, will be out of the scope of "WARRANTY".
- Do not pour water or steam on electrical components.
- Place a container or a pan underneath the oil port to receive waste liquid so that such liquid cannot be spilled out on the floor or inside the machine.
- Be sure that no waste liquid is disposed of on the ground. Such waste on the ground, river or lake will cause serious environmental contamination. Be sure to follow the local regulations. If harmful material such as oil, antifreeze solution or filters are disposed of incorrectly, the responsible person should be punished by the authority.
- Observe local regulations when disposing of such toxic materials as oil, fuel, coolant (anti-freeze), filters, and battery etc.

5. Periodic Inspection/Maintenance

5.2 Daily Inspection and Keeping Operation Log

- Be sure to carry out daily inspection every morning before operation. See Chapter 4 “OPERATION” of the manual for the details of inspection.
- Pay attention to and carefully observe the following points during daily operation or inspection and maintenance work. If any trouble or abnormality is found, immediately investigate its cause and make repairs. If the cause is unknown or not traceable, or if the trouble involves a part or component not described in the manual, ask your nearest dealer for information.

- (a) Controls and instruments function properly.
- (b) Quantity and any leak of water, fuel, and oil or any contamination should be checked.
- (c) Appearance, abnormal noise or excessive heat should be checked.
- (d) Loose bolt or nut should be checked.
- (e) Any damage, wear or shortage of machine components and parts should be checked.
- (f) Performance of each part or component should be proper.

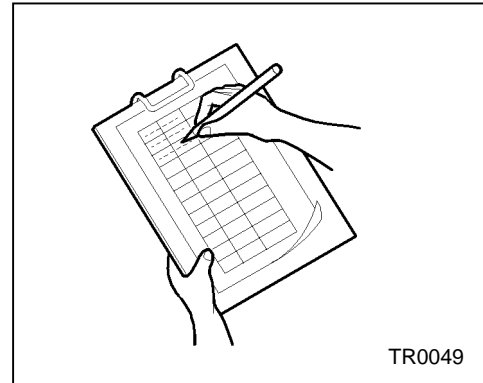

- Keep the operation log to record constant inspection of each component, so that trouble of the machine can be easily discovered and preventive measures can be taken.
It is very useful to record information such as frequency, temperature, current, maintenance items and replenishment of lubricant on a daily maintenance log.

5.3 Periodic Replacement of Parts

IMPORTANT

Use our genuine elements

- Air filter is a crucial component for the performance and the life of a unit.
Use genuine part for replacement.
- Part number changes upon modification. For replacement of parts, make sure whether the part number is correct or applicable.

Part Name	Part Number	Quantity
Engine oil filter	ISUZU 113240 2321	1
Air filter element	32143 12700	1
Fuel filter	ISUZU 113240 0791	1
Filter inside Fuel Air-bleeding Electric Pump	ISUZU 894337 0220	1
V-belt	ISUZU 113671 3270	1

5. Periodic Inspection/Maintenance

5.4 Periodic Inspection List

Such items marked shall be carried out by customers.

For the following items or clauses marked , contact us directly or our distributors because they require expert technical knowledge on them.

Refer to engine operation manual for inspection and maintenance of an engine.

(Unit : Hour)

Maintenance	Daily	50	250	500	1,000	Page	Remarks
Generat	Check Ground of Machine Package and Leakage Relay.					4-13	
	Check each instrument and monitor lamp.					4-16	
	Check insulation resistance.			(Every 2 months)		5-5	
	Check leakage relay operation.			(Every 2 months)		5-6	
	How to check thermal relay.			(Every 2 months)		5-6	
Engine	Check and Clean Clogging of Air Filter Element.					5-7	Perform cleaning when the display lamp glows.
	Change Air Filter Element					5-9	
	Drain fuel tank.					5-7	
	Check Sedimentor					4-12	
	Check fuel level.					4-12	
	Check engine oil level.					4-11	
	Check coolant level.					4-11	
	Check looseness in pipe connector terminals and tear in wiring.				(Every 4 months)	5-8	
	Check V-belt tension.					4-13	In the case of NG, it exchanges.
	Change engine oil.		(First time)			5-4	
	Change engine oil filter.		(First time)			5-5	
	Check battery electrolyte.					5-8	
	Check Specific gravity of battery electrolyte					5-8	
	Change fuel filter.					5-8	
	Change filter inside the fuel air-bleeding electromagnetic pump					5-9	
	Clean the strainer provided inside the engine feed pump.					5-9	
	Check engine valve clearance.						
	Adjust fuel injection nozzle.						
	Check fuel injection timing.						
	Change coolant.(LLC)					5-10	Replaced every 2 years
Clean outside of radiator.					5-8	Dirt condition cleans.	
Check rubber hose.					5-10	Replaced every 2 years	
Clean inside the fuel tank.							

5. Periodic Inspection/Maintenance

5.5 Maintenance

5.5.1 Change Engine Oil

[At 50 hours for the first change and every 500 hours thereafter]

CAUTION

Caution in filling or draining engine oil

- When checking, replenishing, and draining the engine oil, be sure to wait 10 to 20 minutes after engine stops until it cools down.
- Engine oil is very hot and highly pressurized during or just after the operation. Hot oil could blow out and can cause injury.

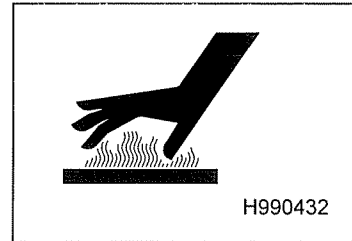

<Procedure>

- ① Remove the drain plug "1" fitted outside the frame, using a spanner etc. Then open the drain valve "2" to drain engine oil.
- ② After finishing draining oil, surely close drain plug "1" and drain valve "2" in reverse procedures. Then supply oil through oil filler port "3" .
- ③ After finishing the oil supply, tighten the cap of oil filter port "3" firmly.

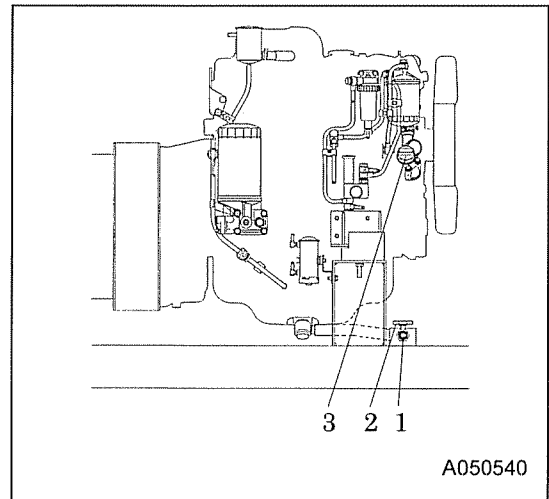

5. Periodic Inspection/Maintenance

5.5.2 Change Engine Oil Filter

[At 50 hours for the first change and every 500 hours thereafter]

<Procedure>

- ① When installing a new oil filter "1", spread oil over the packing "2", and then screw it in. When the packing touches the sealing surface, further tighten the filter by approximately two-thirds turn with a filter wrench.
- ② After the oil filter "1" is assembled, check if there are any oil leaks during operation. (See 5.3)

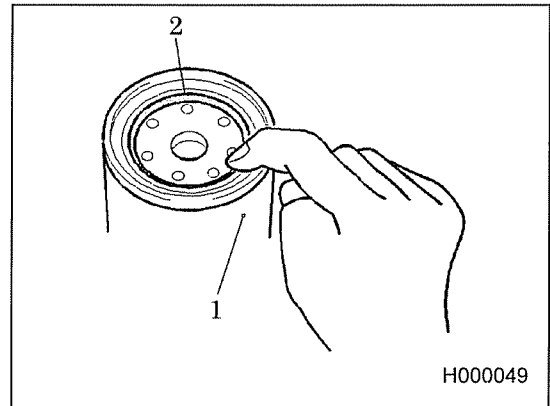

5.5.3 Check Insulation Resistance

[Every two months or every 250 hours]

IMPORTANT

- When the generator has not been operated for a long time or rainwater has got inside the machine, be sure to measure the insulation resistance. If it is reduced to lower than $1M\Omega$, it could cause an electrical leakage or a fire. Dry up the generator main unit until the resistance exceeds $1M\Omega$, then start operating.
- Make sure that no foreign matters are meshed between rotor and stator etc, and also check for dust or dirt because these things such as humidity, oil and dust sticking to the unit deteriorate the insulation.
- After cleaning the main part of the generator as disposal of insulated recovery, there is a method of putting an electric bulb into the inside of the main part of the generator main unit, or sending a hot wind into an inside. Under the present circumstances, it is more effective if the whole main part of the generator main unit is dried in the state where it covered with the sheet. However, please let the bending way and average dry local overheating as notes. Coil surface temperature should not exceed $80\sim 90^{\circ}C$. Even if it carries out the above disposal, when you do not recover, contact us directly or our distributors.

<Procedure>

- ① Remove the load side cable from the output terminal board.
- ② Remove the AVR connector "1" inside the machine control panel.
- ③ Switch ON the circuit breaker "2", measure each insulation resistance between the terminals U, V, W terminal and bonnet.
- ④ If insulation resistance when measured with a 500V megger tester is over $1M\Omega$, it is good.

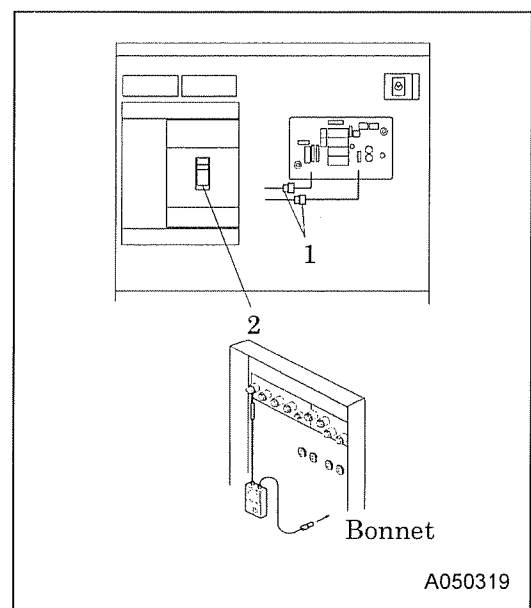

5. Periodic Inspection/Maintenance

5.5.4 Check Leakage Relay Operation

[Every 2 months or every 250 hours]



- Never attempt to test the leakage relay by way of human body.
- In case the leakage relay has tripped due to leakage, always investigate the cause to remove it.

Regularly check the relay operation for safety.

<Procedure>

- ① Start up the machine according to the procedure in 4.8.1.
- ② Turn the circuit breaker (dedicated to single phase) and the other breaker to “ON”.
- ③ Push the leakage relay test button “1”. When the red lamp on the leakage relay and the “LEAKED” lamp “2” on the instrument panel glow, the relay function is normal if the circuit breaker is switched off.
- ④ To set the breaker ON once again, push the leakage relay reset button “3” and set the breaker lever back to the “OFF” position.

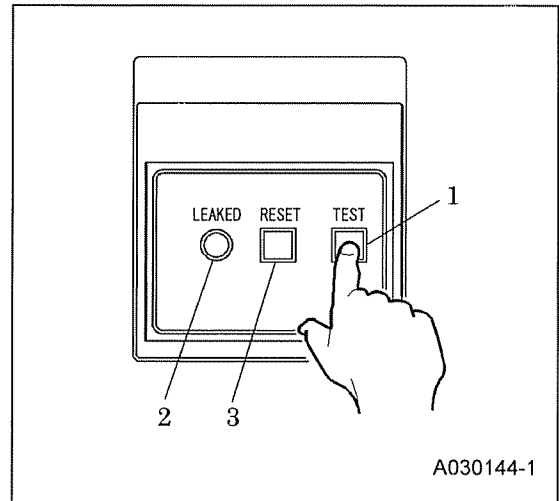

5.5.5 How to check thermal relay

[Every two months or every 250 hours]

<Procedure>

- ① Turn the starter switch to ON.
- ② Turn the circuit breaker (dedicated to single phase) and the other breaker to “ON”.
- ③ Push the test button of the thermal relay in the “arrow” direction, and then both circuit breakers can “TRIP”.
- ④ It is possible to return the circuit breakers to “ON” position again by placing the lever of the breakers to “OFF” position again.

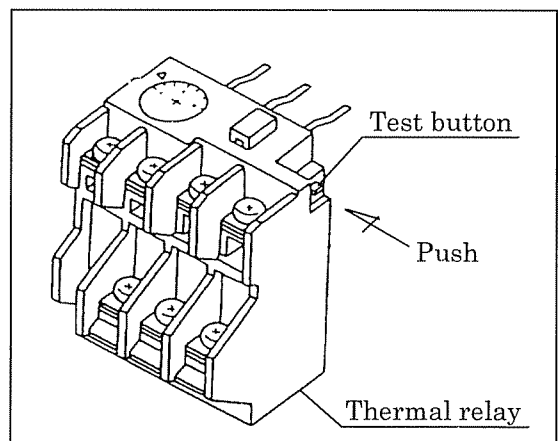

5. Periodic Inspection/Maintenance

5.5.6 Check and Clean Clogging of Air Filter Element

[Every 250 hours]

IMPORTANT

Be sure to properly clean air filter element

- When an element that is clogged or has holes or cracks is used, dust or foreign material will get in the engine. This causes accelerated wear in each sliding part of the engine. Be sure to make daily check and cleaning so that the life of the engine will not be shortened.

- When the air filter monitor lamp glows, clean the air filter.

< Procedure >

After removing the cap "1" by loosening its latch "2", clean its interior properly.

Remove the element "3", and clean it.

When installing the cap "1" after finishing the cleaning job, push the element into the case "4" surely by hand, and then make sure that the latch "2" fixing the cap surely hooks the case "4". Finally tighten it.

If the element is found heavily dusty, replace it with a new one. (see 5.3)

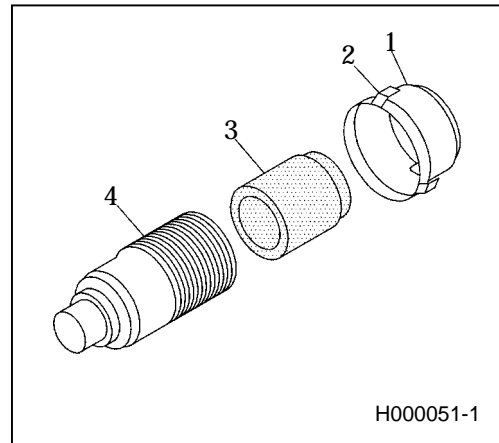

5.5.7 Drain Fuel Tank

[Every 250 hours]

- Fuel tank drain is loosen the drain valve "1" located outside the frame to discharge condensate left in the tank.
- When completely drained, firmly close the drain valve "1".
- Dispose of condensate according to the designated regulations.

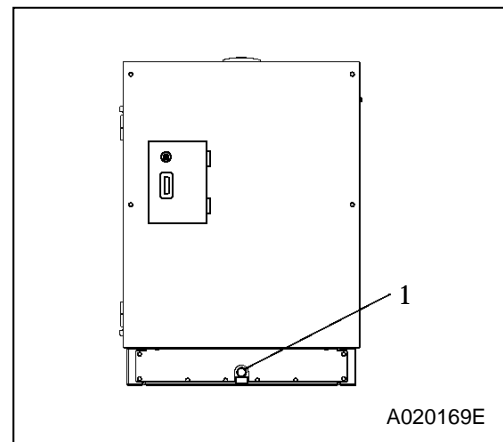

5. Periodic Inspection/Maintenance

5.5.8 Check Battery electrolyte and specific gravity of battery electrolyte

[Battery electrolyte : every 250 hours]

[Specific gravity of battery electrolyte : every 500 hours]

If there to be a problem in starting an engine due to a flat battery, carry out the checks by following the procedures below:

(1) Ordinary type battery:

Measure specific gravity of battery electrolyte, and if it shows below 1.24, recharge the battery immediately. (See 6.1)

(2) Enclosed type battery:

Check the indicator on top surface of the battery.

If the indicator shows that charge is needed, recharge the battery immediately.

5.5.9 Check Wiring of Each Part

[Every 4 months or every 500 hours]

Check each wiring for any loose connection, damage, disconnection, and short circuit.

5.5.10 Change Fuel Filter

[Every 500 hours]

< Procedure >

Take out the cartridge by using a filter wrench.

After coating fuel on the new cartridge " 1 " packing " 2 " , screw it in. (See 5.3)

When the packing " 2 " touches the seal face, tighten it by approximately two-thirds turn using a filter wrench.

Bleed the air of fuel. (See 4.8.6)

After installing a fuel filter, check for fuel leakage during operation.

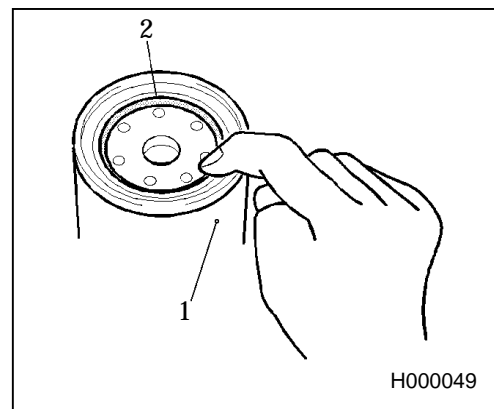

5.5.11 Clean outside of Radiator

[Every 500 hours]

- When the fin tubes " 1 " of radiator are clogged by dust or other foreign materials, the heat exchange efficiency drops and this will raise coolant temperature. These tubes and fins should be cleaned depending on the state of dirt inside the tubes even before maintenance schedule.
- Do not use high pressure washer for washing to prevent fin tubes " 1 " from being damaged.
- When the unit is used, installed near seaside and on boat board, clean the radiator using fresh water more times than once a month.

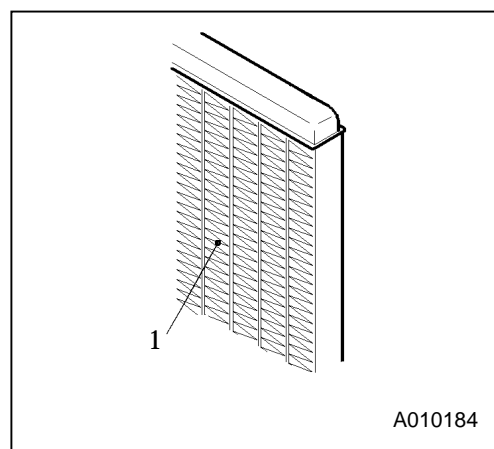

5. Periodic Inspection/Maintenance

5.5.12 Change Filter inside the fuel air-bleeding electromagnetic pump

[Every 1,000 hours]

- Turn the cap "1" counterclockwise to remove it, change the filter "2" inside. (See 5.3.)
- As the fuel inside spills out when it is removed, prepare a fuel receiver.

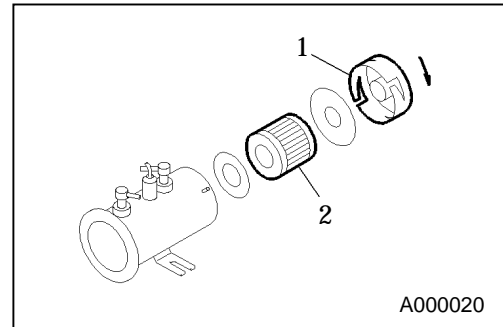

5.5.13 Clean the strainer provided inside the engine feed pump

[Every 1,000 hours]

- Periodically remove the strainer "1" inside the feed pump, and clean it.
- Remove the strainer "1" by loosening the joint bolt and clean it with diesel fuel oil, and also using high air pressure blow. At this time be sure to replace gasket. Then after finishing all cleaning jobs, install it again in reverse steps.

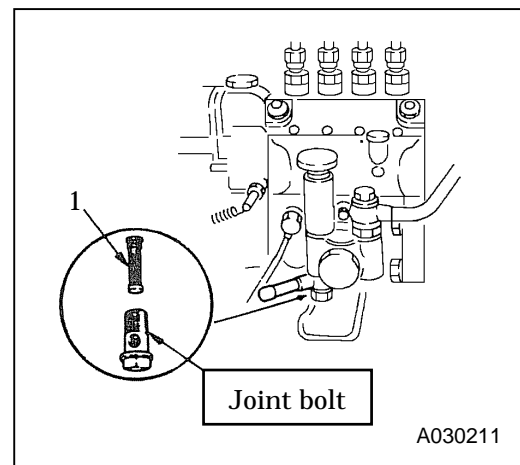

5.5.14 Change Air Filter Element

[Every 1,000 hours]

IMPORTANT

Be sure to properly clean air filter element

- When an element that is clogged or has holes or cracks is used, dust or foreign material will get in the engine. This causes accelerated wear in each sliding part of the engine. Be sure to make daily check and cleaning so that the life of the engine will not be shortened.

< Procedure >

After removing the cap "1" by loosening its latch "2", clean its interior properly.

Remove the element "3" and then replace it with a new one. (see 5.3)

When installing the cap "1" after replacing it, properly push the element into the case "4" by hand and then make sure that the hooks for fixing the cap are surely set. Finally tighten it.

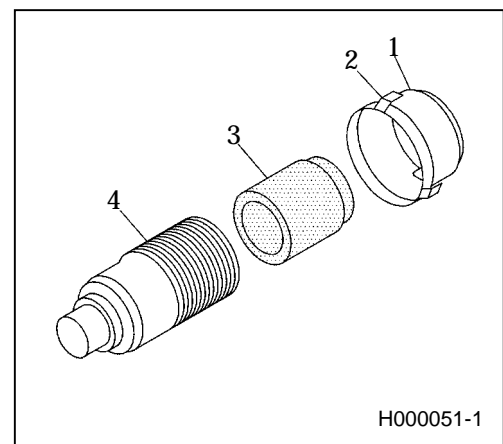

5. Periodic Inspection/Maintenance

5.5.15 Change Coolant

[Every 2 years]



CAUTION

Upon changing coolant

- Be sure to stop the machine and loosen the radiator cap slowly, after the coolant water is sufficiently cooled and the inner pressure is released, then take the cap off.
If the following procedures are neglected, the radiator cap could be blown by the internal pressure or hot moisture air be blown out to cause burning. Therefore, make sure to carry out them without fail.
- LLC (Antifreeze) is a toxic material.
- When a person has drunk LLC (Antifreeze) by accident, make him vomit and make him see a doctor immediately.
- When a person gets LLC (Antifreeze) in his eyes, wash the eyes with clean running water and make him see a doctor immediately.
- When LLC (Antifreeze) is stored, put it in a container with an indication saying "LLC (Antifreeze) inside" and seal it up, then Keep it in a place away from children.
- Beware of flames.

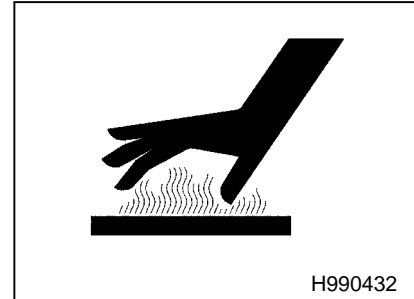

< Procedure >

To drain coolant, remove the radiator cap " 1 " , then loosen the drain valve " 2 " .

Be sure to also unfasten the drain plug " 3 " on the engine cylinder block for drainage.

When the coolant is completely drained out, close each drain valve " 2 " and drain plug " 3 " , and supply new coolant from the filler port of radiator " 4 " .

After changing the coolant, run the engine under unload operation for 2 to 3 minutes, then stop it. Check the coolant level again and replenish it if necessary.

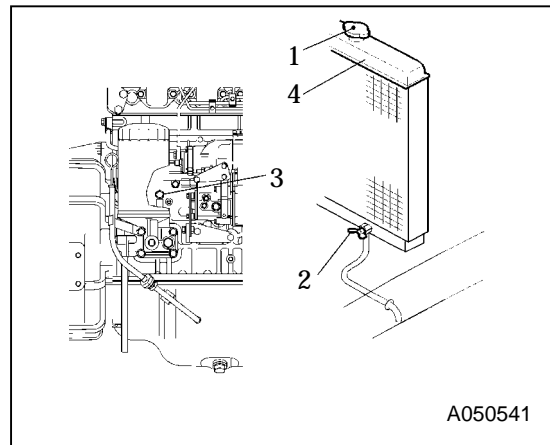

5.5.16 Check Rubber hose

[Every 2 years or every 1,000 hours]

- Rubber hoses (for air filter, radiator, fuel line, and condensate etc.) become hardened or deteriorated, replace them even before the specified hours or periodical intervals.
- Ask your nearest dealer for its replacement.

6. Maintenance/Adjustment

6.1 Maintenance of Battery



Handling battery

- Keep flames away from battery.
- Battery may generate hydrogen gas and may explode. Therefore, recharging should be done at a well-ventilated place.
- Do not spark near the battery nor light a match, nor bring lit cigarette and match close to the battery.
- Do not check the battery by short-circuiting the positive and negative terminals with a metallic piece.
- Never operate the machine nor charge the batteries with the battery liquid level being kept lower than the "LOWER" level. Continuing operation at this lower level will cause deterioration of such parts as pole plates etc., and also it may cause explosion as well as reduction of battery life. Add distilled water so that the liquid level may reach the middle level between the "UPPER" and "LOWER" level without any delay.
- Do not charge the frozen battery. Otherwise it may explode. If the battery is frozen, warm it up until the battery temperature becomes 16°C to 30°C.
- Battery electrolyte is dilute sulfuric acid. In case of mishandling, it could cause skin burning.
- Wear protective gloves and safety glasses when handling a battery.
- When such battery electrolyte contacts your clothes or skin, wash it away with large amount of water immediately.
- If the battery electrolyte gets into your eyes, wash it away immediately with plenty of water and see a doctor at once, because it is feared that eyesight might be lost.
- Dispose of battery, observing local regulations.



D004

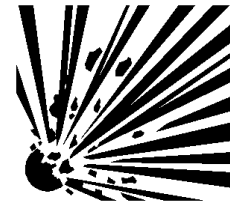

W010



TR0093

6. Maintenance/Adjustment

6.1.1 Charge Battery

- Disconnect the cable between battery and the unit, and charge the battery with a 12 V battery charger. Do not charge two batteries at the same time.
- Be sure not to connect (+) and (-) terminals backwards.
- Be sure to read the operation manual of the battery charger to know if it is applicable, before using it.

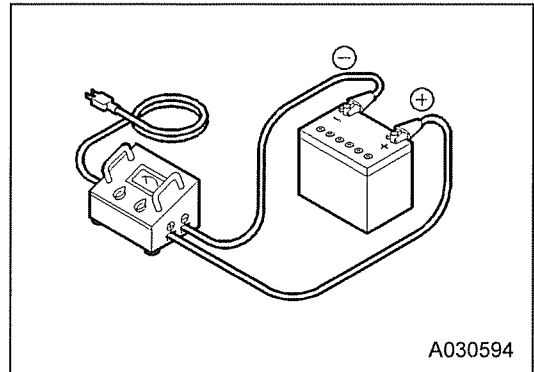

6.1.2 How to Use Booster Cable

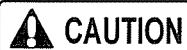

Do not connect the cable reversely

- When a booster cable has to be used or when cables are connected again after an battery is replaced, be careful not to connect (+) and (-) terminals backwards. Such wrong-connection will cause spark and damage to each component.

< Procedure for using a booster cable >

- ① Stop the engine.
- ② Connect one end of the (+) cable to the (+) terminal of the machine battery.
- ③ Connect the other end of the (+) cable to the (+) terminal of the external battery.
- ④ Connect one end of the (-) cable to the (-) terminal of the external battery.
- ⑤ Connect the other end of the (-) cable to the engine block of the machine.
- ⑥ Start up the engine.
- ⑦ Disconnect the booster cable by following the procedure back in the reverse order.

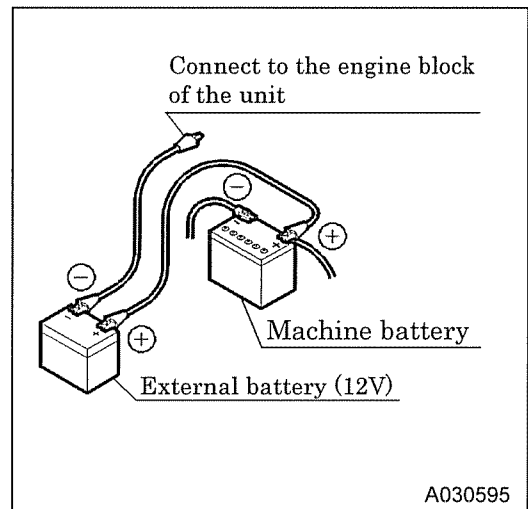

6. Maintenance/Adjustment

6.2 Troubleshooting

- Should any trouble occur during operation, do not leave it. Investigate the cause and take appropriate measures.
- Read the manual carefully and fully understand what to do in case of trouble.
- The better you understand the construction and function of the unit, the faster you can find a problem and solution.
- This chapter describes the state, cause and countermeasures of important troubles in detail:

Symptom	Cause	Counter measures
Starter does not rotate. Low starter revolution speed even when starting.	(1)Battery malfunction	Check Battery Charge/Change
Starter rotates but engine does not start up.	(1)Fuel filter clogging (2)Filter of fuel air-bleeding electric pump clogging (3)Fuel shut-off solenoid malfunction (4)No diesel fuel oil (5)Air mixing in fuel pipings	Disassemble, clean, and change Change filter Check fuse Change solenoid Check connector Replenish fuel Bleed air
Engine oil pressure drop monitor lamp glows.	(1)Engine oil shortage (2)Engine oil filter clogging (3)Oil pressure switch malfunction (4)Loosened or disconnected wiring, or connector	Replenish fuel Change Change Check/repair
Coolant temperature rise monitor lamp glows.	(1)Radiator clogging (2)Faulty thermostat (3)Faulty coolant temperature switch (4)Shortage of coolant (5)Slip of fan belt (6)Looseness, disconnection of wiring or connectors	Clean Change Change Replenish Adjust tension Check/repair
Leakage monitor lamp glows.	(1)Leakage on generator side (2)Leakage on load side (3)Leakage on connecting cable (4)Defective leakage relay	Check/repair Check/repair Check/repair Check/repair
Recharging monitor lamp glows.	(1)Alternator problem (2)Looseness, disconnection of wiring or connector	Check/change Check/repair
The monitor lamp for air filter clogging flickers.	(1) Air filter clogging	Clean

6. Maintenance/Adjustment

Symptom	Cause	Counter measures
Even when operated at a rated speed, no voltage or too low voltage generated.	(1) Faulty voltmeter (2) Poor tightening of terminals (3) Broken or short-circuited winding of generator main unit (4) Faulty AVR (5) Faulty silicon rectifier (mounted on generator main unit rotor) (6) Faulty exciter (7) Broken or short-circuited circuit to exciter field winding (8) AVR frequency selection switch is not set to meet the frequency to be operated. (9) Function circuit protector (CP) for AVR protection	Check/change Check/repair Check/repair Check/change Check/change Check/repair Check/repair Check/select Reset
Too high voltage generated when set at the rated frequency (50Hz/60Hz), Voltage will not drop even when the voltage regulator controlling knob is turned.	(1) Loosened or disconnected wiring, or connector to AVR (2) Faulty AVR (3) Broken wire or poor contact of AVR variable resistor	Check/repair Check/change Repair or change
Unstable voltage generation	(1) Poor tightening of each terminal (2) Faulty AVR (3) Function circuit protector (CP) for AVR protection	Check/repair Check/change Reset

- Please contact your nearest dealer if you find it difficult to repair by yourselves.
- Please refer to the engine operation manual for troubles concerning the engine.

7. Storage of the Unit

7.1 Preparation for Long-term Storage

When the unit is to be kept unused in storage for a long time, be sure to follow the preparations below and put the unit in a dry and less dusty place.

- Put the unit in a temporary cabin if it is stored outside. Avoid leaving the unit outside with a sheet cover directly on the paint for a long time, or this will cause rust to the unit.
- Perform the following treatments at least once every three months.

(Procedure)

Discharge existing lubricant from the engine oil pan. Pour new lubricant in the engine to clean its inside. After running it for a while, drain it again.

Spread lubricant on each moving part.

Completely charge the battery and disconnect grounding wires. Remove the battery from the unit, if possible, and store it in a dry place. (Charge the battery at least once every month.)

Discharge coolant and fuel from the unit.

Seal air-intake port of engine and other openings like the muffler with a vinyl sheet, packing tape, etc., to prevent moisture and dust from getting in the unit.

Be sure to repair any trouble and maintain the unit so that it will be ready for the next operation.



WARNING

Stacking up box type machines

- When stacking up the machines for storage, only two units stacking is acceptable. The mass of the lower machine should be larger than that of the upper one.
- Select a leveled floor with sufficient strength.
- Before stacking the machines up, check the machine for deformation of bonnet, looseness or missing of bolts, and other parts.
- When stacking them, be sure to securely fix them as shown in the figure so that the balanced weight is applied to each squared lumber for preventing a sideslip or a collapse.
- Never operate the machines with stacking conditions. It is very dangerous.
- Machines stacked could fall down due to sideslip or collapse when an earthquake occurs. Therefore, safety should be sufficiently considered for surroundings of storage places.

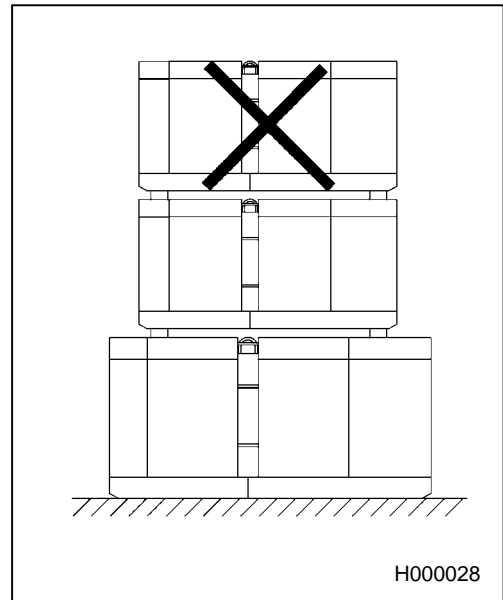

8. Specifications

8.1 Specifications

Model			SDG60S-3A6				
Specifications			Double Voltage Type				
Generator	Exciting system		Brushless system				
	Phase number		Three-phase, four-wire system				
	Power factor		80				
	Frequency		50		60		
	Rated output		50		60		
	Rated output		40		48		
	Voltage		200	400(380)	220	440	
	Current		144	72.0(76.0)	157	78.5	
	Single phase output	Voltage		100		110	
		Exclusive terminal		7.5 × 2		8.25 × 2	
Outlet		1.5 × 2		1.65 × 2			
Engine	Model		ISUZU BB-4BG1T				
	Type		4-cycle, water-cooled, direct injection type with turbo charged				
	Number of cylinders		4				
	Total displacement		4.329				
	Rated output		48.1		57.4		
	Revolution per minute		1,500		1,800		
	Lubricating oil capacity		14				
	Coolant capacity (including radiator)		15				
	Battery		80D26R-MF (12V)				
	Fuel tank capacity		135				
Weight · Mass	Overall length		2,090				
	Overall width		860				
	Overall height		1,220				
	Net dry mass		1,120				
	Operating mass		1,260				

8. Specifications

8.2 Outline drawing

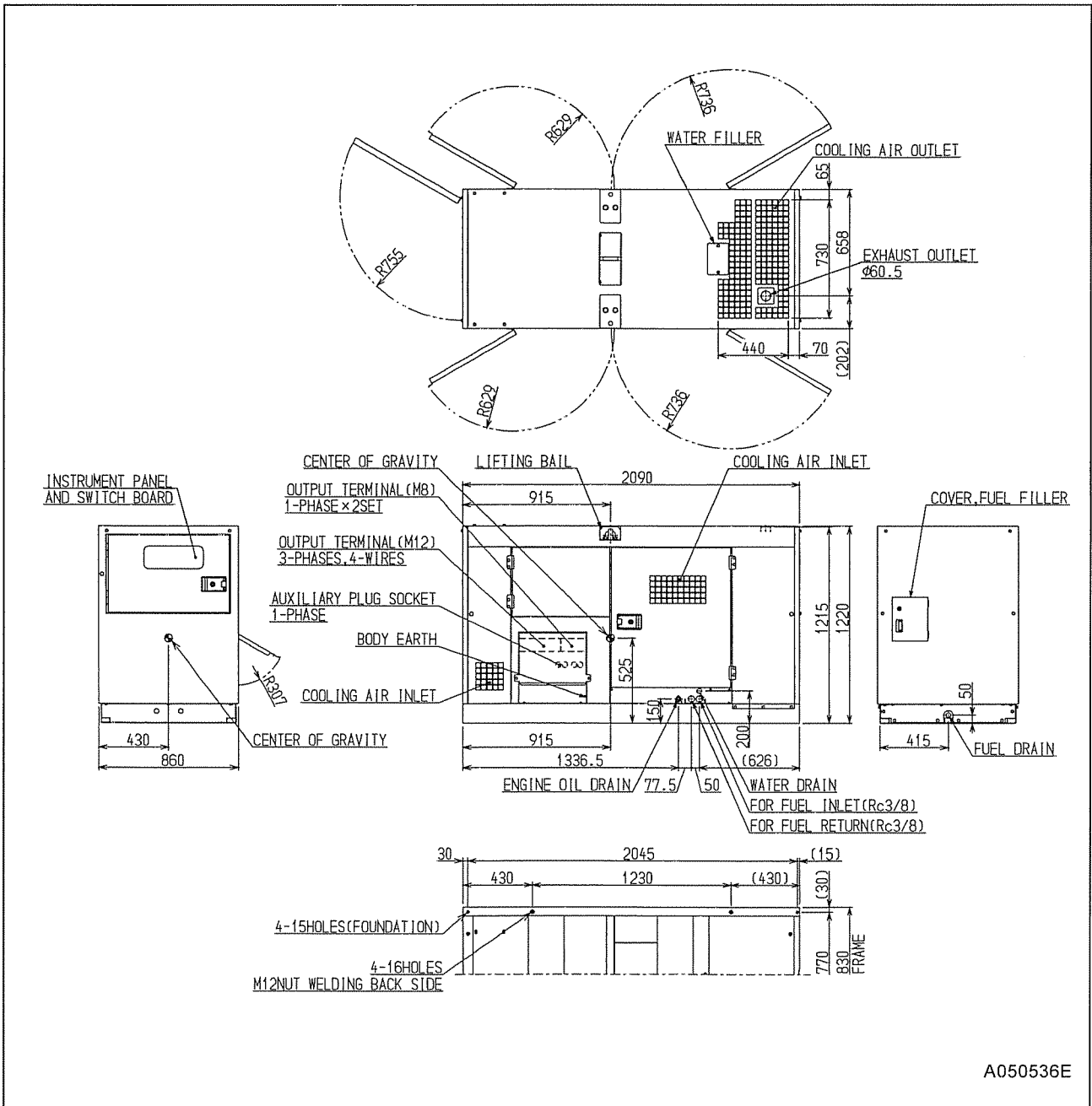

A050536E

9. Wiring Diagram

9.1 Generator Wiring Diagram

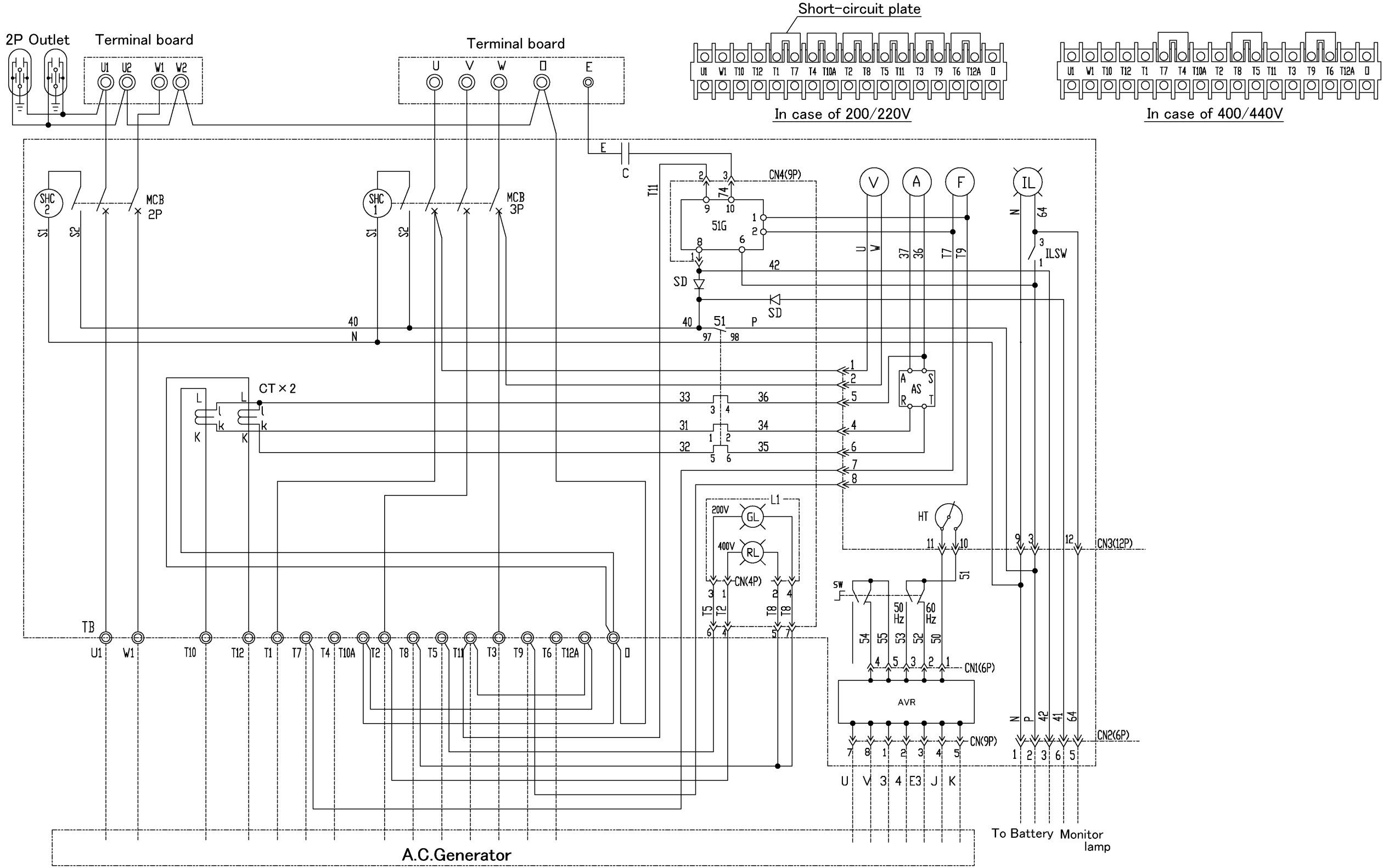

9. Wiring Diagram

9.2 Engine Wiring Diagram

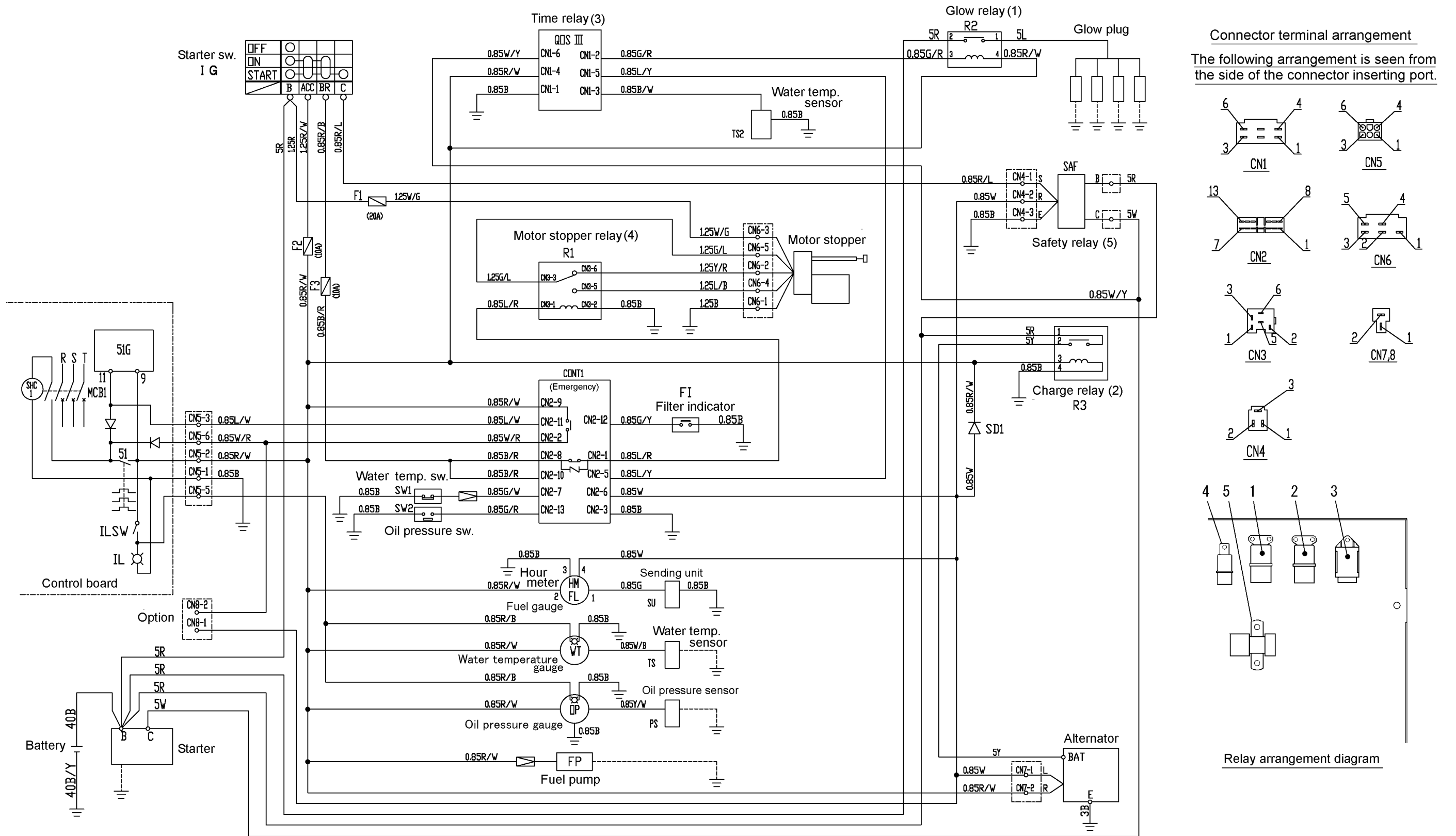

HOKUETSU INDUSTRIES CO., LTD.

12TH FLOOR SHINJUKU SAN-EI BLDG,
22-2 NISHI-SHINJUKU 1-CHOME, SHINJUKU-KU
TOKYO 160-0023 JAPAN
TEL:TOKYO 813(3348)7281
FAX:TOKYO 813(3348)7289
URL:<http://www.airman.co.jp>

39600 66220

PRINTED IN JAPAN 2005.12